

## ELECTRIC TOOL PARTS LIST

■ SLIDE COMPOUND SAW  
Model C 10FSH

2002 · 10 · 10  
(E1)

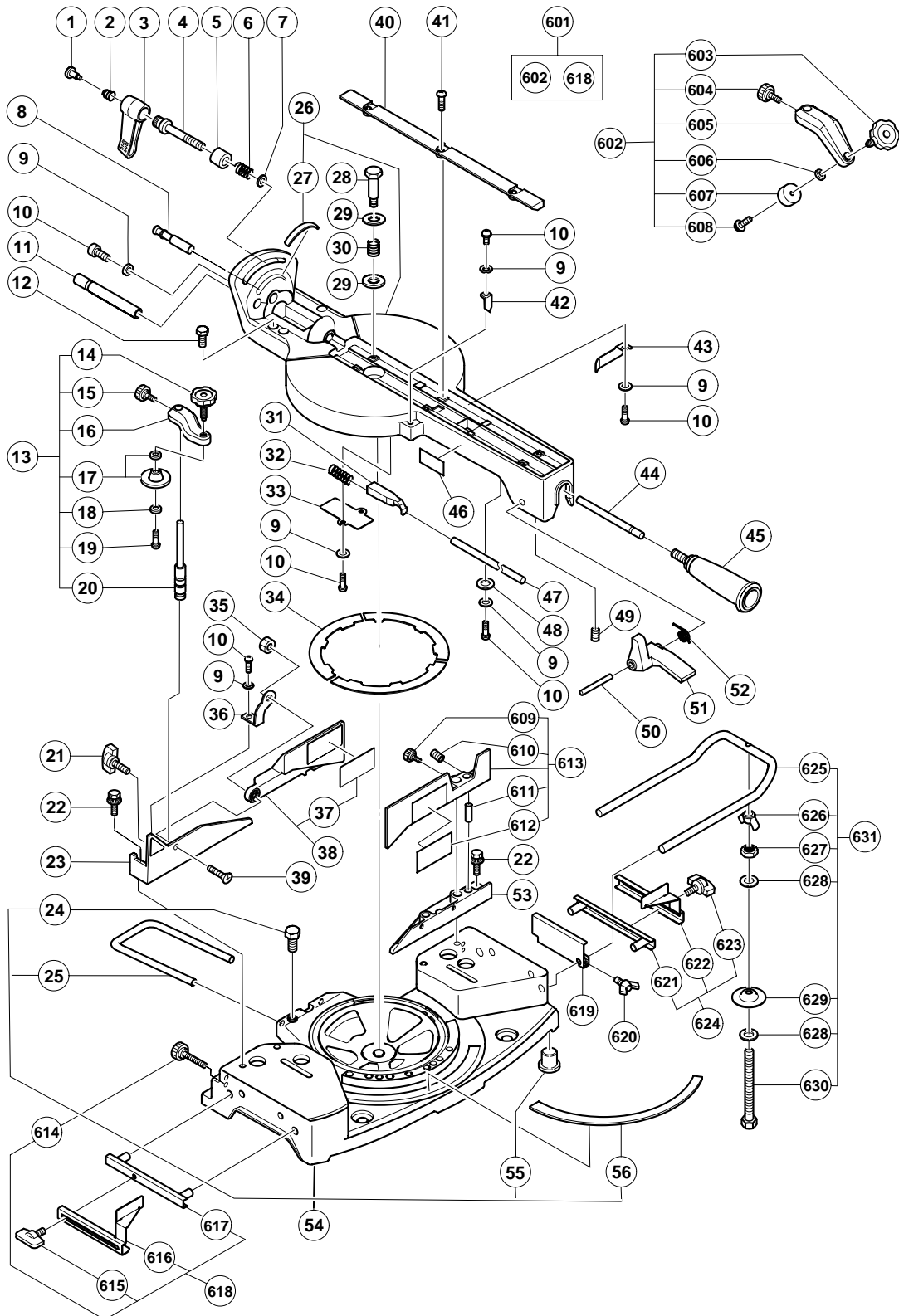

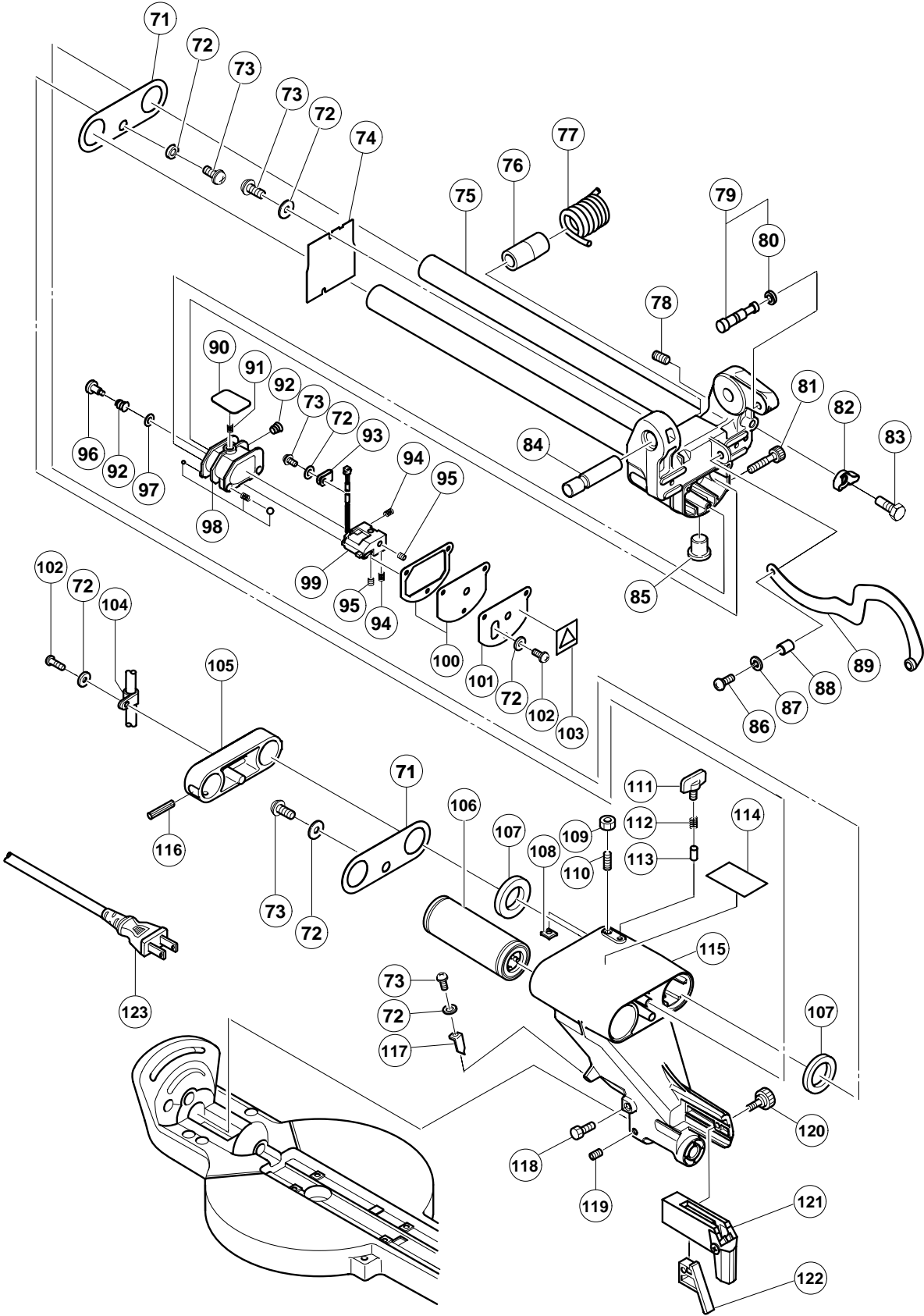

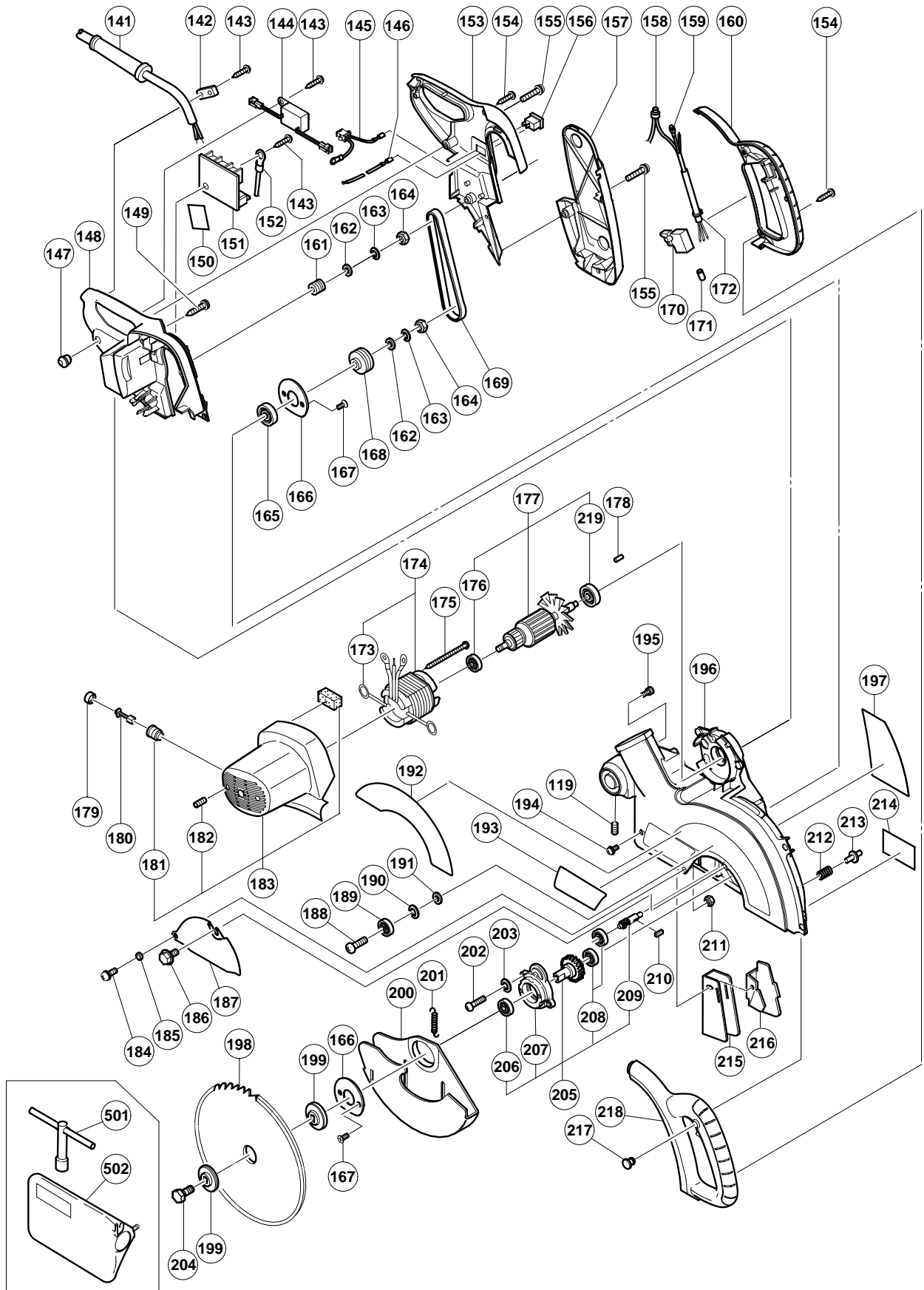

## PARTS

C 10FSH

ITEM NO.	CODE NO.	DESCRIPTION	NO. USED	REMARKS
1	305-180	CLUTCH SCREW	1	
2	305-179	CLUTCH SPRING	1	
3	312-488	CLAMP LEVER	1	
4	307-725	BOLT (LEFT HAND) M10	1	
5	315-195	SLEEVE	1	
6	305-190	METAL SPRING (A)	1	
7	965-077	SPECIAL WASHER	1	
8	321-330	SET PIN (A)	1	
9	949-429	BOLT WASHER M4 (10 PCS.)	8	
10	949-215	MACHINE SCREW M4X8 (10 PCS.)	8	
11	320-141	HINGE SHAFT (A)	1	
12	303-409	NYLOCK BOLT M8X25	2	
13	321-370	WISE ASS'Y	1	INCLUD. 14-20
14	308-396	KNOB BOLT M10	1	
15	998-836	KNOB BOLT M6X11	1	
16		SCREW HOLDER	1	
17	319-974	WISE PLATE SET	1	
18	996-722	WASHER	1	
19	996-247	MACHINE SCREW (WWASHERS) M5X12 (BLACK)	1	
20	321-371	WISE SHAFT	1	
21	302-459	WING BOLT M6X17	1	
22	307-221	BOLT (WWASHERS) M8X35 (BLACK)	4	
23	321-346	FENCE (B)	1	
24	949-610	BOLT M6X10 (10 PCS.)	1	
25	998-844	HOLDER	1	
26	321-412	TURN TABLE ASS'Y	1	INCLUD. 27
27	321-343	SCALE (B)	1	
28	312-480	SHAFT (B)	1	
29	949-437	BOLT WASHER M12 (10 PCS.)	2	
30	312-481	SPRING	1	
31	321-335	STOPPER (A)	1	
32	321-417	SPRING (E)	1	
33	321-336	PIN COVER	1	
34	998-811	LINER	3	
35	311-144	NYLON NUT M6	1	
36	321-331	PLATE	1	
37	321-386	WARNING LABEL (H)	1	
38	321-385	SUB FENCE (B) ASS'Y	1	INCLUD. 37
39	949-342	FLAT HD. SCREW M6X25 (10 PCS.)	1	
40	319-549	TABLE INSERT	2	
41	949-258	MACHINE SCREW M6X20 (10 PCS.)	6	
42	321-329	INDICATOR	1	
43	321-342	SPACER (A)	1	
44	321-341	SHAFT (A)	1	
45	976-805	SIDE HANDLE	1	
46		CAUTION LABEL (K)	1	
47	321-337	SHAFT (C)	1	
48	875-249	THRUST WASHER	2	
49	987-860	SEAL LOCK HEX. SOCKET SET SCREW M6X6	1	
50	321-339	LEVER SHAFT	1	
51	321-338	LEVER	1	

## PARTS

C 10FSH

ITEM NO.	CODE NO.	DESCRIPTION	NO. USED	REMARKS
52	321-340	SPRING (D)	1	
53	321-345	FENCE (A)	1	
54	321-372	BASE ASS'Y	1	INCLUD. 24, 25, 55, 56
55	312-672	BASE RUBBER	4	
56	315-210	SCALE (A)	1	
71	996-227	PACKING COVER	2	
72	949-429	BOLT WASHER M4 (10 PCS.)	11	
73	949-215	MACHINE SCREW M4X8 (10 PCS.)	6	
74	321-349	COVER	1	
75	321-351	HINGE (A) ASS'Y	1	INCLUD. 105
76	996-276	SLEEVE	1	
77	321-332	SPRING	1	
78	961-554	HEX. SOCKET SET SCREW M8X10	1	
79	302-518	STOPPER PIN ASS'Y	1	INCLUD. 80
80	984-528	O-RING (P-6)	1	
81	319-270	ADJUSTER	1	
82	949-312	WING NUT M8 (10 PCS.)	1	
83	949-633	BOLT M8X50 (10 PCS.)	1	
84	320-141	HINGE SHAFT (A)	1	
85	312-672	BASE RUBBER	1	
86	949-237	MACHINE SCREW M5X12 (10 PCS.)	1	
87	949-454	SPRING WASHER M5 (10 PCS.)	1	
88	998-980	SPACER	1	
89	321-368	LINK	1	
90	319-268	PLATE (B)	1	
91	319-267	SPRING	1	
92	305-179	CLUTCH SPRING	2	
93	980-523	NYLON CLIP	1	
94	319-267	SPRING	2	
95	319-541	SEAL LOCK HEX. SOCKET SET SCREW M5X6	2	
96	305-180	CLUTCH SCREW	1	
97	962-614	ADJUSTING WASHER (B) T0.5	1	
98	319-269	HOLDER (B)	1	
99	321-348	LASER MARKER	1	
100	319-271	COVER (A)	1	
101	319-272	PLATE (A)	1	
102	949-217	MACHINE SCREW M4X12 (10 PCS.)	5	
103		CAUTION LABEL (J)	1	
104	948-193	NYLON CLIP	1	
105	321-352	SUPPORT	1	
106	321-347	BALL BUSHING	1	
107	996-226	FELT	2	
108	996-223	BUSHING	2	
109	949-568	LOCK NUT M8 (10 PCS.)	2	
110	974-500	HEX. SOCKET SET SCREW M8X16	2	
111	302-459	WING BOLT M6X17	1	
112	947-859	LOCK SPRING	1	
113	963-174	CLAMP PIECE (B)	1	
114	320-206	CAUTION LABEL (A)	1	
115	321-375	HOLDER (A)	1	
116	949-686	ROLL PIN D6X40 (10 PCS.)	2	

**PARTS**

C 10FSH

ITEM NO.	CODE NO.	DESCRIPTION	NO. USED	REMARKS
117	321-329	INDICATOR	2	
118	303-409	NYLOCK BOLT M8X25	1	
119	307-956	SEAL LOCK HEX. SOCKET SET SCREW M6X10	2	
120	302-503	KNOB BOLT M6X22	1	
121	321-333	GUARD (A)	1	
122	321-394	GUARD HOLDER	1	
123	500-241Z	CORD	1	
141	938-051	CORD ARMOR D10.1	1	
142	937-631	CORD CLIP	1	
143	984-750	TAPPING SCREW (W/FLANGE) D4X16	4	
144	321-378	SWITCHING POWER SUPPLY	1	
145	321-376	CONNECTOR (B)	1	
146	321-377	INTERNAL WIRE	1	
147	319-349	CORD BUSH	1	
148	321-550	HANDLE (L)	1	
149	305-558	TAPPING SCREW (W/FLANGE) D5X25 (BLACK)	3	
150	321-355	SHEET	1	
151	321-354	CONTROLLER	1	
152	930-804	TERMINAL M4.0 (10 PCS.)	1	
153	321-380	HANDLE (R)	1	
154	301-653	TAPPING SCREW (W/FLANGE) D4X20 (BLACK)	6	
155	880-734	MACHINE SCREW (W/WASHERS) M5X25 (BLACK)	4	
156	319-503	SWITCH (W/COVER)	1	
157	321-383	PULLEY COVER	1	
158	959-141	CONNECTOR 50092 (10 PCS.)	2	
159	980-063	TERMINAL	1	
160	321-381	SWITCH HANDLE (R)	1	
161	321-356	PULLEY (A)	1	
162	949-426	WASHER M8 (10 PCS.)	2	
163	978-559	SUPER LOCK WASHER	2	
164	949-558	NUT M8 (10 PCS.)	2	
165	620-1VV	BALL BEARING 6201VVCMP2L	1	
166	307-731	COVER	2	
167	949-322	FLAT HD. SCREW M4X10 (10 PCS.)	4	
168	321-357	PULLEY (B)	1	
169	307-736	BELT (170H10)	1	
170	998-839	SWITCH (1P PILLAR TYPE) W/LOCK	1	
171	981-373	TUBE (D)	3	
172	321-532	CORD (A) ASS'Y	1	INCLUD. 159, 171
173	975-884	BRUSH TERMINAL	2	
174	340-539D	STATOR ASS'Y 120V	1	INCLUD. 173
175	953-174	HEX. HD. TAPPING SCREW D5X55	2	
176	321-399	BALL BEARING 608VVC2NS7L	1	
177	360-588U	ARMATURE ASS'Y 120V	1	INCLUD. 176, 219
178	976-441	BEARING LOCK	1	
179	945-161	BRUSH CAP	2	
180	999-043	CARBON BRUSH (1 PAIR)	2	
181	958-900	BRUSH HOLDER	2	
182	938-477	HEX. SOCKET SET SCREW M5X8	2	
183	321-379	HOUSING ASS'Y	1	INCLUD. 181, 182
184	996-247	MACHINE SCREW (W/WASHERS) M5X12 (BLACK)	1	

**PARTS**

C 10FSH

ITEM NO.	CODE NO.	DESCRIPTION	NO. USED	REMARKS	
185	998-980	SPACER	1		
186	996-577	BOLT (W/WASHERS) M6X12 (BLACK)	1		
187	318-958	SPINDLE COVER	1		
188	949-258	MACHINE SCREW M6X20 (10 PCS.)	1		
189	606-ZZM	BALL BEARING 606ZZC2PS2L	1		
190	949-455	SPRING WASHER M6 (10 PCS.)	1		
191	949-425	WASHER M6 (10 PCS.)	1		
192		HITACHI LABEL	1		
193		WARNING LABEL (G)	1		
194	304-043	MACHINE SCREW (W/WASHERS) M4X10 (BLACK)	1		
195	877-839	SEAL LOCK HEX. SOCKET HD. BOLT M5X10	1		
196	321-384	GEAR CASE	1		
197		WARNING LABEL (M)	1		
198	310-878	TCT SAW BLADE 255MM-D15.88 HOLE-NT40	1		
199	308-789	WASHER (D)	2		
200	321-367	SAFETY COVER	1		
201	315-710	RETURN SPRING	1		
202	949-241	MACHINE SCREW M5X20 (10 PCS.)	2		
203	949-454	SPRING WASHER M5 (10 PCS.)	2		
204	998-335	BOLT (LEFT HAND) W/WASHER M7X17.5	1		
205	308-787	SPINDLE ASS'Y	1	INCLUD.206-209	
206	600-3DD	BALL BEARING 6003DDCMPS2S	1		
207	308-788	BEARING HOLDER	1		
208	608-VVM	BALL BEARING 608VVC2PS2L	2		
209		PINION	1		
210	931-008	FEATHER KEY 4X4X12	1		
211	949-555	NUT M5 (10 PCS.)	1		
212	988-821	LOCK SPRING	1		
213	307-732	STOPPER PIN	1		
214		NAME PLATE	1		
215	321-364	DUST GUIDE	1		
216	312-492	GUIDE HOLDER	1		
217	951-895	LOCK-OFF BUTTON	1		
218	321-382	SWITCH HANDLE (L)	1		
219	321-398	BALL BEARING 6201VVCMNS7S	1		

## STANDARD ACCESSORIES

C 10FSH

ITEM NO.	CODE NO.	DESCRIPTION	NO. USED	REMARKS
501	940-543	BOX WRENCH 10MM	1	
502	998-845	DUST BAG	1	

## OPTIONAL ACCESSORIES

ITEM NO.	CODE NO.	DESCRIPTION	NO. USED	REMARKS
601	321-434	CROWN MOLDING VISE ASS'Y	1	INCLUD. 602, 618
602	321-388	VISE (B) ASS'Y	1	INCLUD. 603-608
603	321-551	KNOB BOLT M10X54	1	
604	998-836	KNOB BOLT M6X11	1	
605		SCREW HOLDER (B)	1	
606	306-985	WASHER (H)	1	
607	964-851	BASE RUBBER	1	
608	304-043	MACHINE SCREW (W/WASHERS) M4X10 (BLACK)	1	
609	960-017	KNOB BOLT M6X32	1	
610	987-860	SEAL LOCK HEX. SOCKET SET SCREW M6X6	2	
611	321-552	PIN	2	
612		WARNING LABEL (L)	1	
613	321-387	SUB FENCE (A) ASS'Y	1	INCLUD. 609-612
614	960-017	KNOB BOLT M6X32	1	
615	301-806	WING BOLT M6X15	1	
616		CROWN MOLDING STOPPER (L)	1	
617	321-390	CROWN MOLDING STOPPER HOLDER	1	
618	321-374	CROWN MOLDING STOPPER (L) ASS'Y	1	INCLUD. 614-617
619	974-561	STOPPER	1	
620	949-404	WING BOLT M6X20 (10 PCS.)	1	
621	321-390	CROWN MOLDING STOPPER HOLDER	1	
622		CROWN MOLDING STOPPER (R)	1	
623	301-806	WING BOLT M6X15	1	
624	321-373	CROWN MOLDING STOPPER (R) ASS'Y	1	INCLUD. 614, 621-623
625	321-549	HOLDER	2	
626	949-313	WING NUT M6 (10 PCS.)	2	
627	949-556	NUT M6 (10 PCS.)	2	
628	967-329	WASHER (H)	4	
629	996-261	VISE PLATE	2	
630	996-283	HIGH TENSION BOLT M6X65	2	
631	321-553	GUIDE ASS'Y	1	INCLUD. 614, 619, 620, 625-630