

ENGINE TOOL PARTS LIST

■ BRUSH CUTTER
Model CG 42EA

2005 · 2 · 25
(E1)

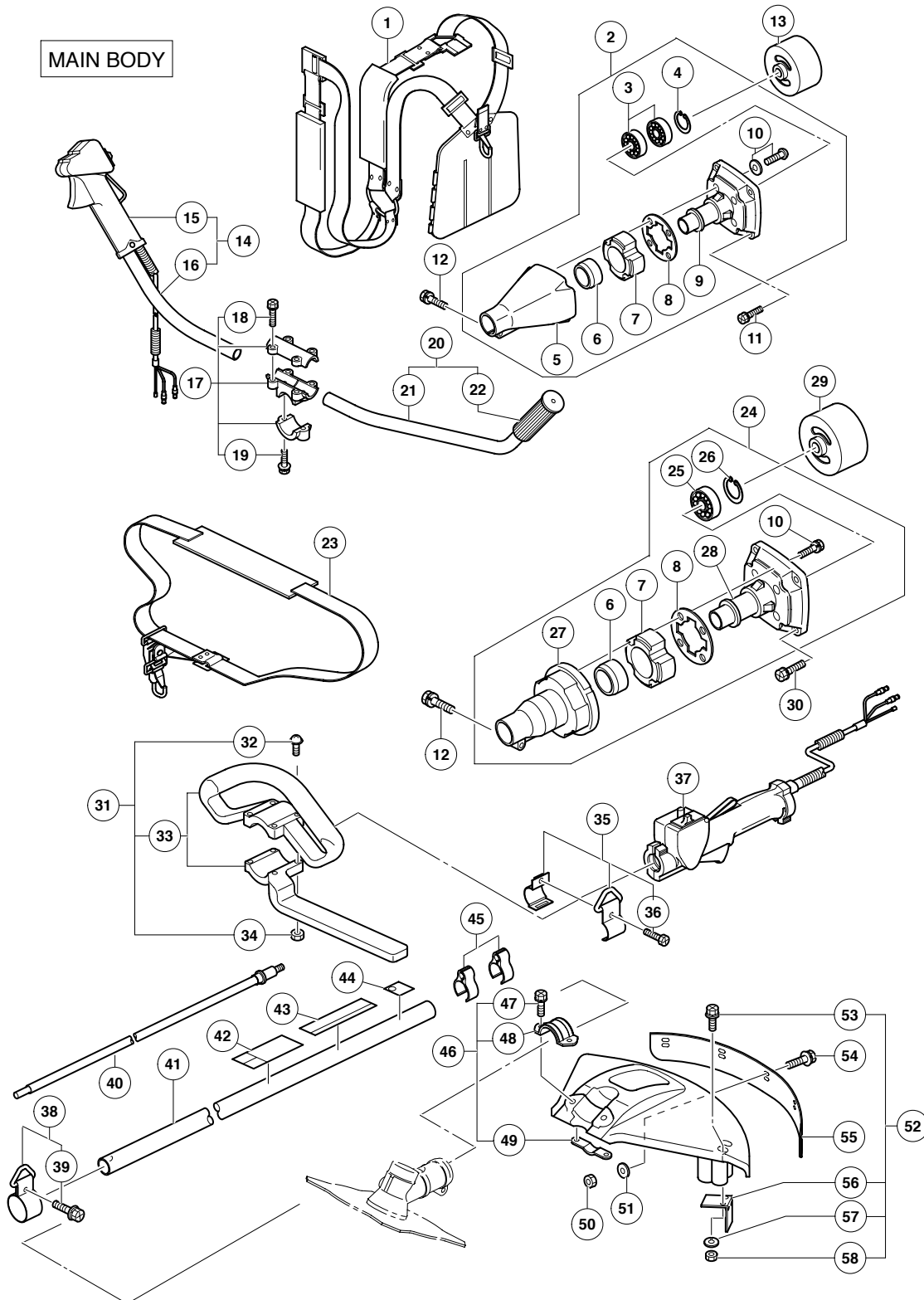

GEAR CASE

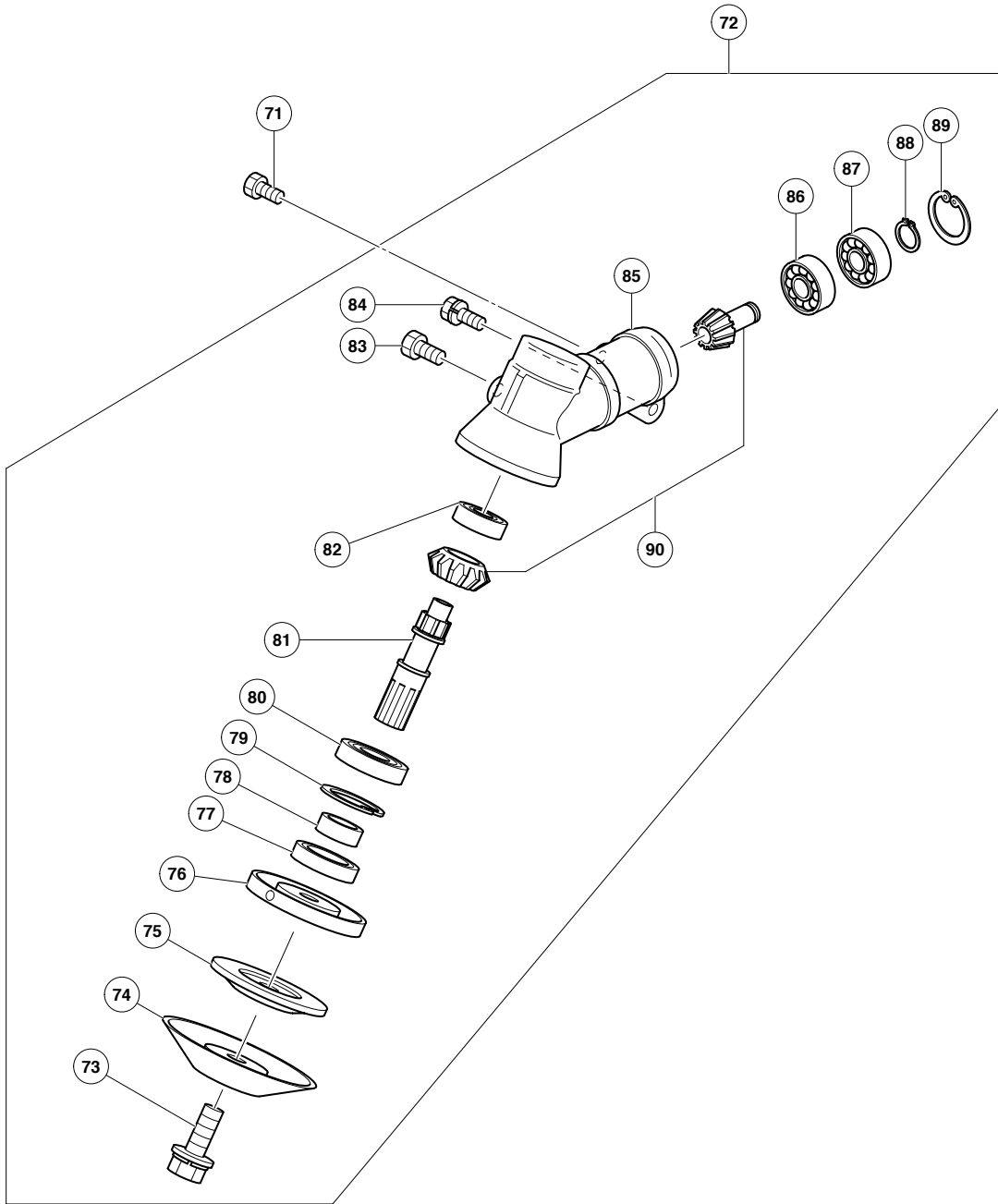

ENGINE

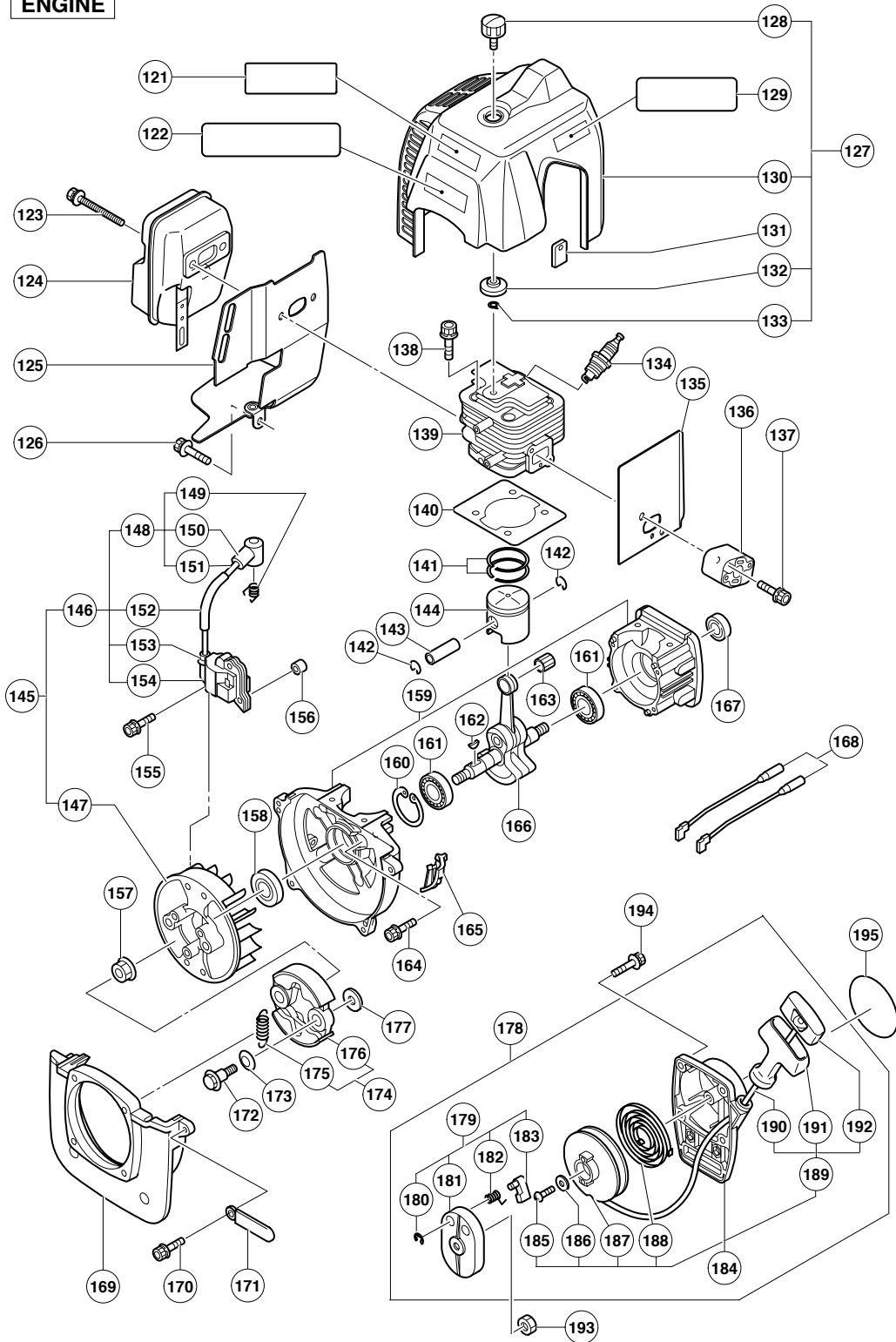

CARBURETOR , FUEL TANK

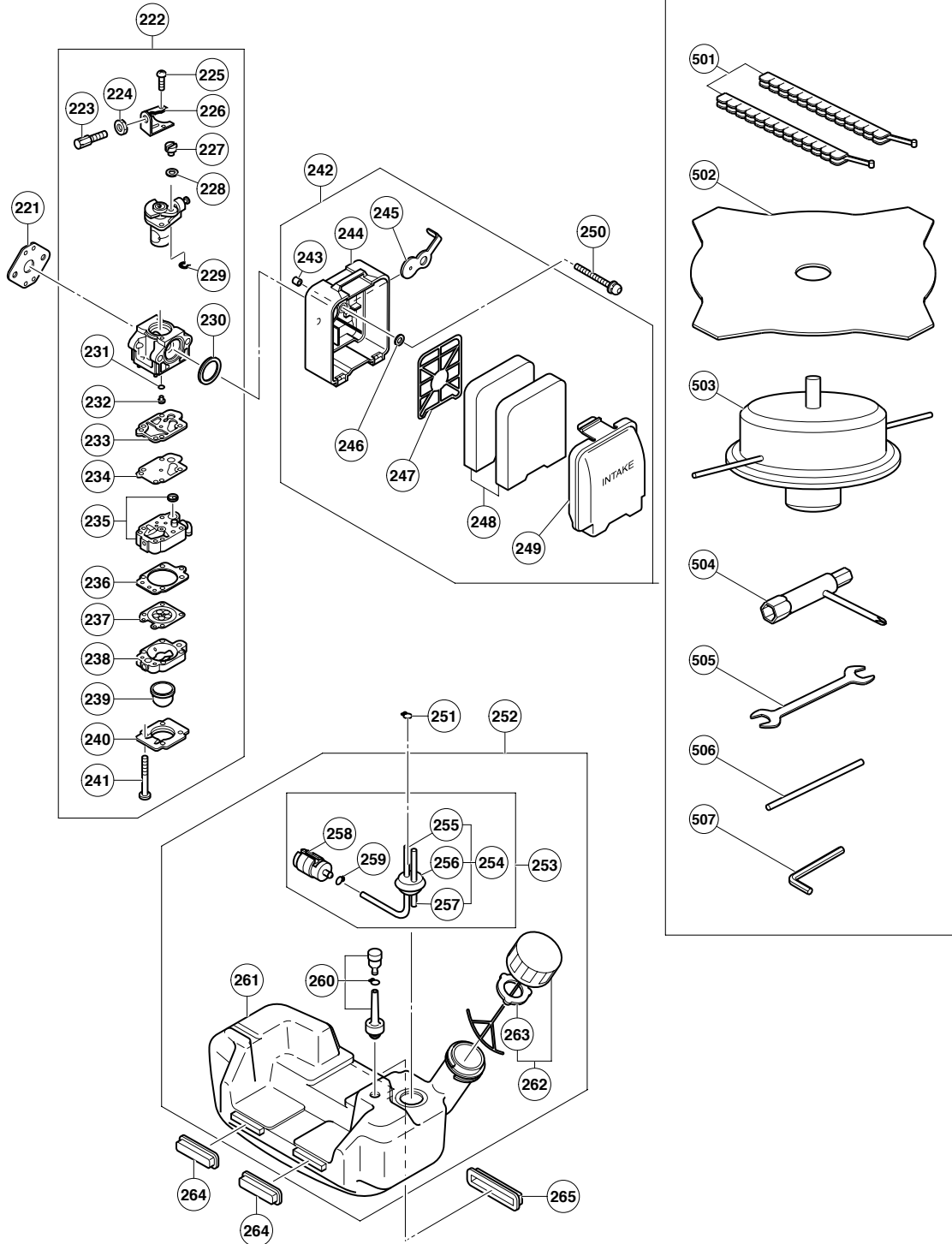

PARTS

CG 42EA

ITEM NO.	CODE NO.	DESCRIPTION	NO. USED	REMARKS
		MAIN BODY		
* 1	683-239	HANGING STRAP	1	FOR CG 42EA
* 2	683-217	CLUTCH CASE ASS'Y	1	INCLUD. 3-10 FOR CG 42EA
* 3	683-219	BEARING 620ZZ	2	FOR CG 42EA
* 4	683-220	SNAP RING H35	1	FOR CG 42EA
* 5	683-224	DRIVE SHAFT TUBE ADAPTER	1	FOR CG 42EA
	683-222	BUFFER (B)	1	
	683-221	BUFFER (A)	1	
	683-223	WASHER	1	
* 9	683-218	BEARING CASE	1	FOR CG 42EA
	683-131	SCREW (W/SP. WASHER) M5X15	4	
* 11	683-240	BOLT (W/SP. WASHER) M6X20	4	FOR CG 42EA
	683-225	BOLT (W/WASHERS) M6X30	1	
* 13	683-226	CLUTCH DRUM	1	FOR CG 42EA
* 14	683-236	HANDLE (B) ASS'Y	1	INCLUD. 15, 16 FOR CG 42EA
* 15	683-238	THROTTLE TRIGGER	1	FOR CG 42EA
* 16	683-237	HANDLE (B)	1	FOR CG 42EA
* 17	683-230	HANDLE BRACKET ASS'Y	1	INCLUD. 18, 19 FOR CG 42EA
* 18	683-231	BOLT (W/WASHERS) M6X25	4	FOR CG 42EA
* 19	683-225	BOLT (W/WASHERS) M6X30	2	FOR CG 42EA
* 20	683-233	HANDLE (A) ASS'Y	1	INCLUD. 21, 22 FOR CG 42EA
* 21	683-234	HANDLE (A)	1	FOR CG 42EA
* 22	683-235	HANDLE GRIP	1	FOR CG 42EA
* 23	683-002	HANGING STRAP	1	FOR CG 42EA (SL)
* 24	683-244	CLUTCH CASE ASS'Y	1	INCLUD. 6-8, 10, 25-28 FOR CG 42EA (SL)
* 25	683-246	BEARING 6201ZZ	1	FOR CG 42EA (SL)
* 26	683-170	SNAP RING H32	1	FOR CG 42EA (SL)
* 27	683-247	DRIVE SHAFT TUBE ADAPTER	1	FOR CG 42EA (SL)
* 28	683-245	BEARING CASE	1	FOR CG 42EA (SL)
* 29	683-248	CLUTCH DRUM	1	FOR CG 42EA (SL)
* 30	683-254	BOLT M6X20	4	FOR CG 42EA (SL)
* 31	683-251	LOOP HANDLE ASS'Y	1	INCLUD. 32-34 FOR CG 42EA (SL)
* 32	682-990	SCREW (W/SP. WASHER) M5X28	4	FOR CG 42EA (SL)
* 33	682-988	LOOP HANDLE	1	FOR CG 42EA (SL)
* 34	949-555	NUT M5 (10 PCS.)	4	FOR CG 42EA (SL)
* 35	683-250	HANGING BRACKET ASS'Y	1	INCLUD. 36 FOR CG 42EA (SL)
* 36	682-986	BOLT M5X15	1	FOR CG 42EA (SL)
* 37	683-249	THROTTLE TRIGGER	1	FOR CG 42EA (SL)
* 38	683-229	HANGING BRACKET ASS'Y	1	INCLUD. 39 FOR CG 42EA
* 39	682-999	BOLT (W/WASHERS) M5X15	1	FOR CG 42EA
* 40	683-227	DRIVE SHAFT	1	FOR CG 42EA
* 40	683-253	DRIVE SHAFT	1	FOR CG 42EA (SL)
* 41	683-228	DRIVE SHAFT TUBE	1	FOR CG 42EA
* 41	683-252	DRIVE SHAFT TUBE	1	FOR CG 42EA (SL)
		CAUTION LABEL (A)	1	
		HITACHI LABEL	1	
	683-352	NOISE LABEL (C)	1	
* 45	683-232	WIRE GUIDE	2	FOR CG 42EA
	683-241	SAFETY GUARD ASS'Y	1	INCLUD. 47-49
	682-994	BOLT (W/SP. WASHER) M6X30	2	
	683-242	BRACKET	1	

PARTS

CG 42EA

ITEM NO.	CODE NO.	DESCRIPTION	NO. USED	REMARKS
49	683-243	THREADED BRACKET	1	
50	949-555	NUT M5 (10 PCS.)	5	
51	683-000	PLANE WASHER	5	
52	682-995	STRING CUTTER ASS'Y	1	INCLUD. 53, 56-58
53	682-997	BOLT (W/WASHER) M5X25	2	
54	682-999	BOLT (W/WASHERS) M5X15	5	
55	682-998	EXTENSION	1	
56	682-996	STRING CUTTER	1	
57	949-454	SPRING WASHER M5 (10 PCS.)	2	
58	949-555	NUT M5 (10 PCS.)	2	
		GEAR CASE		
71	683-268	BOLT M6X12	1	
* 72	683-255	GEAR CASE ASS'Y	1	INCLUD. 73-90 FOR CG 42EA
* 72	683-269	GEAR CASE ASS'Y	1	INCLUD. 73-90 FOR CG 42EA (SL)
73	683-018	BOLT (LEFT HAND) W/WASHERS M8X22	1	
74	683-267	STABILIZER	1	
75	683-266	CLAMPING WASHER	1	
76	683-265	BOSS ADAPTER	1	
77	683-261	OIL SEAL	1	
78	683-260	COLLAR	1	
79	683-170	SNAP RING H32	1	
80	683-259	BEARING 6002	1	
81	683-258	BLADE SHAFT	1	
82	683-154	BEARING 609	1	
* 83	683-150	BOLT M8X10 (BLACK)	1	FOR CG 42EA
* 83	683-271	BOLT M8X10 (SILVER)	1	FOR CG 42EA (SL)
84	683-225	BOLT (W/WASHERS) M6X30	1	
* 85	683-256	GEAR CASE	1	FOR CG 42EA
* 85	683-270	GEAR CASE	1	FOR CG 42EA (SL)
86	683-262	BEARING 6000	1	
87	683-263	BEARING 6000Z	1	
88	683-264	SNAP RING H10	1	
89	683-128	SNAP RING H26	1	
90	683-257	GEAR SET	1	
		ENGINE		
121		EMISSION LABEL (C)	1	
122		CAUTION LABEL (B)	1	
123	683-279	CAP SCREW M6X65	2	
124	683-277	MUFFLER	1	
125	683-278	GASKET COMP.	1	
126	683-033	CAP SCREW M5X16	1	
127	683-280	TOP COVER ASS'Y	1	INCLUD. 128, 130, 132, 133
128	683-282	KNOB	1	
129	683-351	CE LABEL	1	
130	683-281	TOP COVER	1	
131	683-181	GROMMET	1	
132	683-283	SPACER	1	
133	683-284	SNAP RING H6	1	
134	683-068	SPARK PLUG (R)	1	
135	683-276	AIR DUCT	1	
136	683-275	INSULATOR	1	

PARTS

CG 42EA

ITEM NO.	CODE NO.	DESCRIPTION	NO. USED	REMARKS
137	683-029	SCREW M5X25	2	
138	683-274	CAP SCREW M5X25	4	
139	683-272	CYLINDER	1	
140	683-273	GASKET (H)	1	
141	683-291	PISTON RING	2	
142	683-294	CLIP PISTON	2	
143	683-292	PISTON PIN	1	
144	683-290	PISTON	1	
145	683-303	MAGNETO ASS'Y	1	INCLUD. 146, 147
146	683-305	IGNITION COIL ASS'Y	1	INCLUD. 148, 152-154
147	683-304	ROTOR	1	
148	683-307	SPARK PLUG CORD ASS'Y	1	INCLUD. 149-151
149	683-061	CONNECTOR	1	
150	683-060	PLUG CAP	1	
151	683-308	CORD	1	
152	683-309	TUBE	1	
153	683-062	CAP	1	
154	683-306	COIL	1	
155	683-067	CAP SCREW M4X25	2	
156	683-066	SPACER	2	
157	683-310	NUT M10	1	
158	683-287	OIL SEAL (D)	1	
159	683-285	CRANK CASE	1	
160	683-220	SNAP RING H35	1	
161	683-286	BEARING 6202C3	2	
162	683-064	WOODRUFF KEY	1	
163	683-293	NEEDLE BEARING	1	
164	683-289	CAP SCREW M5X40	4	
165	683-328	SCREEN	1	
166	683-295	CRANK SHAFT	1	
167	683-288	OIL SEAL (E)	1	
168	683-311	LEAD	2	
169	683-302	COOLING COVER	1	
170	683-087	CAP SCREW M5X20	4	
171	683-088	CLAMP	1	
172	683-301	CLUTCH BOLT	2	
173	683-300	WAVE WASHER	2	
174	683-296	CLUTCH ASS'Y	1	INCLUD. 175, 176
175	683-298	SPRING CLUTCH	1	
176	683-297	CLUTCH SHOE	2	
177	683-299	WASHER M8	2	
178	683-312	RECOIL STARTER ASS'Y	1	INCLUD. 179, 184
179	683-322	STARTER PAWL ASS'Y	1	INCLUD. 180-183
180	683-326	E-RING	1	
181	683-325	PULLEY (A)	1	
182	683-324	RETURN SPRING	1	
183	683-323	RATCHET	1	
184	683-313	RECOIL ASS'Y	1	INCLUD. 185-189
185	683-321	SCREW	1	
186	683-320	WASHER M5.3	1	
187	683-319	PULLEY (B)	1	

PARTS

CG 42EA

ITEM NO.	CODE NO.	DESCRIPTION	NO. USED	REMARKS
188	683-318	SPIRAL SPRING	1	
189	683-314	ROPE ASS'Y	1	INCLUD. 190-192
190	683-316	ROPE	1	
191	683-315	STARTER KNOB	1	
192	683-317	CAP	1	
193	683-327	NUT M8	1	
194	683-163	CAP SCREW M4X16	4	
195		NAME PLATE	1	
		CARBURETOR, FUEL TANK		
221	683-346	GASKET (I)	1	
222	683-329	CARBURETOR ASS'Y	1	INCLUD. 223-241
223	683-199	SCREW	1	
224	683-083	NUT M6	1	
225	683-197	SCREW M3X10	2	
226	683-198	BRACKET	1	
227	683-102	SWIVEL	1	
228	683-201	WASHER M4.85	1	
229	683-101	RING	1	
230	683-200	FRAME	1	
231	683-090	O-RING (I.D. 1.8)	1	
232	683-330	MAIN JET	1	
233	683-092	GASKET (C)	1	
234	683-093	DIAPHRAGM	1	
235	683-094	PUMP BODY	1	
236	683-095	GASKET (D)	1	
237	683-331	DIAPHRAGM (METERRING)	1	
238	683-097	PURGE BODY	1	
239	683-098	PRIMER PUMP	1	
240	683-099	PUMP COVER	1	
241	683-100	SCREW M3X24	4	
242	683-332	AIR CLEANER ASS'Y	1	INCLUD. 243-249
243	683-334	SLEEVE	2	
244	683-333	AIR CLEANER CASE	1	
245	683-208	CHOKE VALVE	1	
246	683-206	WASHER M6.5	1	
247	683-335	PLATE	1	
248	683-336	ELEMENT	2	
249	683-337	AIR CLEANER COVER	1	
250	683-338	CAP SCREW M5X50	2	
251	683-122	CLIP	1	
252	683-339	FUEL TANK ASS'Y	1	INCLUD. 253, 260-262
253	683-341	FUEL PIPE ASS'Y	1	INCLUD. 254, 258, 259
254	683-342	PIPE ASS'Y	1	INCLUD. 255-257
255	683-343	FUEL PIPE	1	
256	683-118	GROMMET	1	
257	683-120	RETURN PIPE 3X6X85	1	
258	683-344	FUEL FILTER	1	
259	683-122	CLIP	1	
260	683-115	BREATHER	1	
261	683-340	FUEL TANK	1	
262	683-113	FUEL TANK CAP ASS'Y	1	INCLUD. 263

