

# H43

# CH55EPA(SM)

**Serial No. :**

MPREF	MPHIN	MPNAM	MPQTY1	MPQT	MPQTY3	MPS
		+++++++ MODEL:CH55EPAM ++++++				
		H43-01 CYLINDER/PISTON/CRANK				
001	157-01570-90	SPARK PLUG CAP ASS'Y	1			
002	018-00555-20	SPARK PLUG, RCJ8Y	1			
006	001-07130-91	CYLINDER SET	1			
007	994-61050-184	HEX. HOLE BOLT 5X18/S	2			
009	017-00980-20	CYLINDER GASKET	1			
011	041-00601-21	PISTON RING	1			
012	030-00070-90	PISTON SET	1			
013	039-00601-20	PISTON PIN CIRCLIP	2			
014	037-06500-20	PISTON PIN	1			
016	046-07135-80	CRANK SHAFT COMP.	1			
040	178-20549-20	HIGH TENSION CORD 140L	1			
043	167-20546-80	IGNITION COIL COMP.	1			
046	994-63040-154	HEX.HOLE BOLT 4X15/PS	2			
050	167-20546-91	IGNITION COIL	1			
056	560-20517-20	RUBBER CAP	1			
057	191-07025-90	REED WIRE ASS'Y	1			
		H43-02 CRANK CASE				
019	330-00200-23	GEAR SHAFT SHIM 0.20	V			
019	330-00200-24	GEAR SHAFT SHIM 0.30	V			
031	072-07120-92	CRANK CASE ASS'Y	1			
032	999-66122-200	OIL SEAL TB 12227	2			
033	999-61600-115	BALL BEARING 6001 C3	2			
034	090-06410-20	CRANK CASE GASKET	1			
036	994-61050-184	HEX. HOLE BOLT 5X18/S	3			
051	155-20550-81	MAGNETO ROTOR COMP.	1			
052	992-01080-011	WASHER 8	1			
054	991-01080-011	HEX. NUT 8	1			
		H43-03 ENGINE-01				
040	403-0631A-20	INLET MANIFOLD GASKET	1			
041	404-0099F-90	CARB INSULATOR SET	1			
042	402-0602K-21	CARBURETOR GASKET	1			
047	994-64050-224	HEX.HOLE BOLT 5X22/WS	2			
055	994-14050-601	SCREW 5X60/S	2			
056	992-01050-011	WASHER 5	2			
059	223-07000-90	SHEELD TUBE	1			
060	680-00731-20	CLIP, 6.3 DIA.	1			
061	675-04042-80	PUMP FILTER BODY COMP.	1			
062	591-07135-21	TANK, OR	1			
063	595-01690-90	TANK CAP ASS'Y (BLACK)	1			
064	659-00801-20	COLLAR 5.8	3			
065	455-07139-90	CARBURETOR SET WYL182	1			
066	560-07120-20	SWIVEL CAP	1			
067	994-63050-164	HEX.HOLE BOLT 5X16/PS	2			
068	994-65050-205	SCREW 5X20WS	1			
073	626-32550-20	TANK CAP CHAIN	1			
078	700-03005-08	FUEL PIPE 3X5X85	1			
079	534-32710-20	RETURN GROMMET	1			
		H43-04 ENGINE-02				
001	738-07162-20	MUFFLER PROTECTOR BLACK	1			
002	994-15040-151	SCREW 4X15PS	1			
004	990-73045-124	TAPPING SCREW 4.5X12	1			
005	990-51050-503	HEX. HOLE BOLT 5X50	2			
006	992-01050-061	WASHER 5	2			
007	704-07001-90	MUFFLER SET	1			
016	737-07000-20	MUFFLER GASKET	1			
017	133-06540-20	HEAT SHIELD	1			
031	359-02103-20	CLUTCH WASHER B	2			
032	290-06410-80	CLUTCH SHOE COMP. , T-16	2			

033	342-06410-20	CLUTCH SPRING	1
034	348-06540-20	CLUTCH PLATE A. O. 3	2
035	357-00601-20	STEP BOLT	2
036	994-64050-184	HEX. HOLE BOLT 5X18/WS	2
038	992-05080-030	BENT WASHER 8	2
045	994-64050-304	HEX. HOLE BOLT 5X30/WS	1
063	198-11600-80	CORD CLAMP COMP.	1
		H43-05 RECOIL STARTER	
000	762-07130-91	RECOIL STARTER BODY ASS'Y	1
001	785-07085-20	STARTER HANDLE	1
003	772-07130-81	RECOIL STARTER BODY COMP.	1
004	783-07130-20	ROPE 2. 6X830	1
005	780-07130-20	RECOIL SPRING	1
006	778-07130-90	SPRING CASE ASS'Y	1
007	774-07130-20	STARTER ROPE REEL	1
008	182-07085-20	SPECIAL WASHER 5. 2X15	1
009	990-72050-144	TAPPING SCREW 5X14	1
016	994-64040-185	HEX. HOLE BOLT 4X18WS	4
020	798-07085-90	STARTER PULLEY ASS'Y	1
021	991-82050-001	FLUNGE NUT 5	1
		H43-06 AIR CLEANER	
000	410-07142-91	CLEANER ASSY	1
001	452-00070-92	CLEANER COVER SET	1
002	421-00070-20	AIRCLEANER ELEMENT	1
003	380-0637C-20	SPECIAL SCREW	1
004	423-00070-81	CLEANER BODY COMP.	1
006	528-07143-80	CHOKE VALVE COMP.	1
007	992-04080-031	WAVE WASHER 8	1
008	657-3252A-20	COLLAR 8	1
		H43-07 CARBURETOR	
002	575-25153-80	PUMP BODY COMP	1
003	442-25151-80	PRIMING PUMP COMP.	1
004	476-25151-20	DIAPHRAGM COVER	1
005	447-25108-20	PRIMING BODY	1
006	474-25241-80	METERING DIAPHRAGM COMP.	1
007	475-25153-20	DIAPHRAGM GASKET	1
008	576-25100-20	PUMP DIAPHRAGM	1
009	577-25100-20	PUMP GASKET	1
010	599-2000W-38	MAIN JET #38	1
011	550-25100-20	O-RING	1
012	489-25100-20	STOP RING	1
013	539-25120-20	SWIVEL	1
015	548-25140-20	THROTTLE SET SCREW	2
020	548-25151-20	SET SCREW	4
201	578-25007-20	INLET SCREEN	1
		H43-08 FAN CASE	
001	289-07060-80	CLUTCH SHAFT COMP.	1
003	993-50012-002	STOP RING C-12, OUTER	1
005	599-07120-21	ANTI-VIBE RUBBER	1
006	990-51050-163	HEX. HOLE BOLT 5X16	1
008	994-61050-254	HEX. HOLE BOLT 5X25/S	1
011	112-07124-80	FAN CASE COMP. OR	1
015	360-00996-20	PIPE HOLDER, 24 DIA.	1
026	992-01050-061	WASHER 5	1
027	324-37350-20	GEAR CASE WASHER	1
028	361-00990-20	METAL FITTING	1
		H43-09 OPERATION PIPE	
001	343-32243-20	DRIVE SHAFT 633L	1
002	341-32243-80	DRIVE SHAFT PIPE 600L	1
003	347-38360-90	BUSH ASS'Y	2
016	335-37526-90	LIFTING METAL ASS'Y	1

017	215-32243-20	BRACKET A	1
018	216-32243-20	BRACKET B	1
019	210-33160-22	FRONT HANDLE	1
025	870-38449-90	THROTTLE LEVER ASS'Y	1
026	990-51050-553	HEX. HOLE BOLT 5X55	2
027	994-81060-254	HEX. HOLE BUTTON SCREW 6X25S	2
028	991-01050-041	NUT 5	2
029	991-01060-041	HEX. NUT 6	2
030	992-01050-061	WASHER 5	2
031	992-01060-061	WASHER 6	2
032	992-10050-062	S. WASHER 5	2
050	746-37540-91	SHOULDER BELT ASS'Y	1
083	885-38449-80	THROTTLE WIRE COMP.	1
084	887-38449-80	THROTTLE WIRE 4T	1
085	156-37821-80	STOP BUTTON COMP.	1
086	164-07014-50	PROTECTION TUBE 7X145L	1
098	253-38400-20	SAFETY LEVER	1
100	832-38400-20	RETURN SPRING	1
103	322-38400-20	BLIND PLUG	1
110	994-31050-203	SCREW 5X20	2
111	991-01050-043	CONTAL NUT 5	2
112	993-46040-202	SCREW 4X20, BLACK	4
125	880-38400-20	THROTTLE LEVER	1
		H43-10 GEAR CASE	
001	300-32287-21	GEAR CASE A, 24 DIA	1
003	999-61690-101	BALL BEARING 6901ZZ, 24MM/OD	2
004	993-52012-002	STOP RING S-12, OUTER	1
005	993-51024-002	STOP RING C-24, INNER	1
006	999-61608-013	BALL BEARING 608 ZZ C3	1
007	993-51022-002	STOP RING C-22, INNER	1
008	300-32250-80	GREASE NIPPLE COMP.	3
011	990-51050-103	HEX. HOLE BOLT 5X10	1
012	994-61050-254	HEX. HOLE BOLT 5X25/S	1
013	990-53060-125	HEX. HOLE BOLT 6X12	2
014	871-32600-20	SPECIAL WASHER B	2
015	301-32286-21	GEAR CASE B	1
016	999-61600-014	BALL BEARING #6000 2RS C3	1
017	993-51026-002	STOP RING C-26, INNER	1
018	871-32600-20	SPECIAL WASHER B	2
019	993-55060-000	STOP RING E-6	1
020	327-32280-20	GEAR CASE COVER A	1
022	990-51040-085	HEX HOLE BOLT 4X8	2
023	999-61608-013	BALL BEARING 608 ZZ C3	1
024	993-51022-002	STOP RING C-22, INNER	1
026	210-32286-20	HANDLE	1
029	990-53060-153	HEX HOLE BUTTON SCREW 6X15	2
030	088-32287-20	GREASE SEALED	1
035	302-32286-01	GEAR SET	1
036	512-32286-80	HANDLE KNOB A COMP.	1
041	990-23060-141	PLUS BOLT 6X14	1
042	991-87060-001	NUT 6 UPS-P	1
043	462-32286-20	SUPPORT PLATE	1
044	086-32286-20	GREASE SEAL B	1
045	222-32286-20	ANGLE LIMITTER	1
046	992-01060-011	WASHER 6	1
		H43-12 BLADE	
001	100-32282-81	CAM SHAFT COMP.	1
002	101-33160-22	CAM ROD	2
003	075-32280-20	CAM-ROD GUIDE PLATE	2
004	122-32286-21	CUTTER GUIDE 625.5MM	1
005	120-32287-21	CUTTER A	2

006	124-32287-20	FIXING BOLT A M6	1
007	129-33202-20	WASHER 7 BLACK	4
008	991-82060-001	FLANGE NUT 6	3
009	990-52060-165	HEX HOLE FLUSH SCREW 6X16	1
010	085-32286-20	GREASE SEAL A	2
011	105-32280-20	CAM-ROD HOLDING PLATE	1
012	328-32286-21	GEAR CASE COVER B	1
013	999-61608-013	BALL BEARING 608 ZZ C3	1
014	994-61040-104	HEX. HOLE BOLT 4X10S	2
015	994-61040-124	HEX. HOLE BOLT 4X12S	6
016	138-33168-20	CUTTER COVER	1
020	125-32287-20	CUTTER FIXING BOLT B	3
021	990-52060-255	HEX. HOLE FLUSH BOLT 6X25	1
022	087-32286-20	GREASE SEAL B	1
023	296-32286-20	SPACER	1
024	136-32286-20	PROTECTION PLATE	1
025	991-87060-001	NUT 6 UPS-P	1
026	992-01060-011	WASHER 6	1
029	036-29331-50	COMBI. BOX SPANNER 10X19 ,PLUS	1
030	813-20000-20	HEX. WRENCH 4	1
		H43-13 LABELS	
001	929-51300-20	SMBOL MARK CH55EPA (SM)	1
002	915-07182-21	STARTER MARK	1
005	919-73800-20	CAUTION MARK HITACHI	1
		===== END OF DATA =====	











# H43-01 CH55EPA(SM) CYLINDER/PISTON/CRANK SHAFT

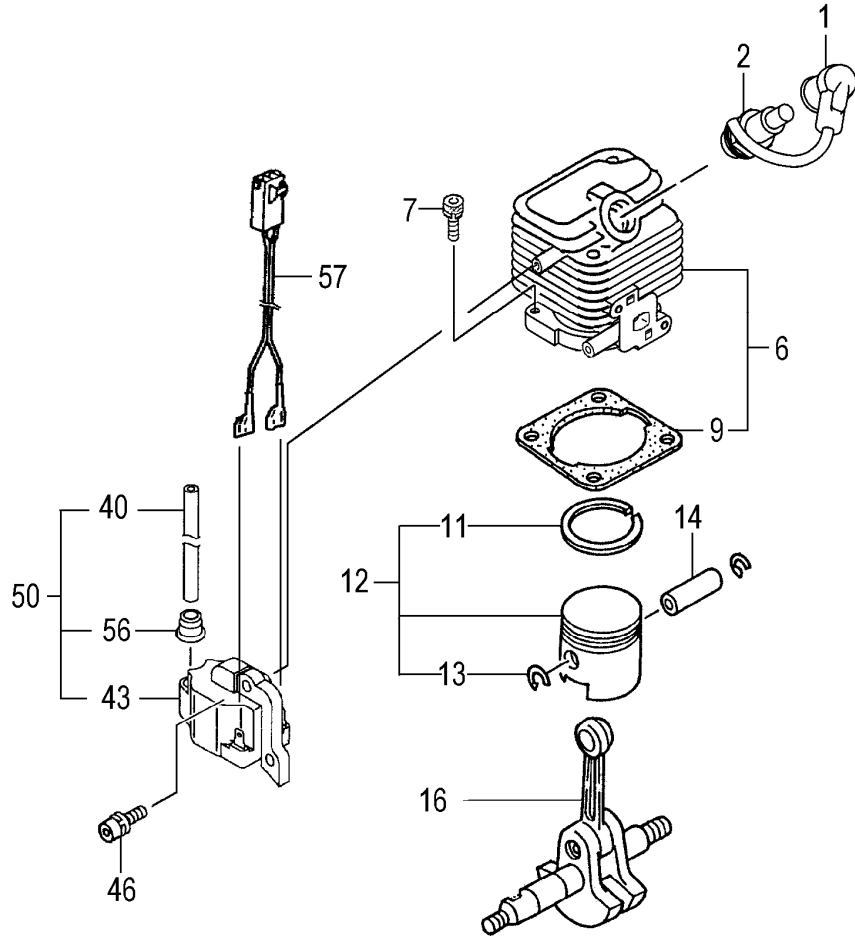

REF. NUMBER	PARTS NUMBER	DESCRIPTION	Q'TY	SERIAL NUMBER
001	157-01570-90	SPARK PLUG CAP ASS'Y	1	
002	018-00555-20	SPARK PLUG, RCJ8Y	1	
006	001-07130-91	CYLINDER SET	1	
007	994-61050-184	HEX. HOLE BOLT 5X18/S	2	
009	017-00980-20	CYLINDER GASKET	1	
011	041-00601-21	PISTON RING	1	
012	030-00070-90	PISTON SET	1	
013	039-00601-20	PISTON PIN CIRCLIP	2	
014	037-06500-20	PISTON PIN	1	
016	046-07135-80	CRANK SHAFT COMP.	1	
040	178-20549-20	HIGH TENSION CORD 140L	1	
043	167-20546-80	IGNITION COIL COMP.	1	
046	994-63040-154	HEX.HOLE BOLT 4X15/PS	2	
050	167-20546-91	IGNITION COIL	1	
056	560-20517-20	RUBBER CAP	1	
057	191-07025-90	REED WIRE ASS'Y	1	

# H43-02 CH55EPA(SM) CRANK CASE

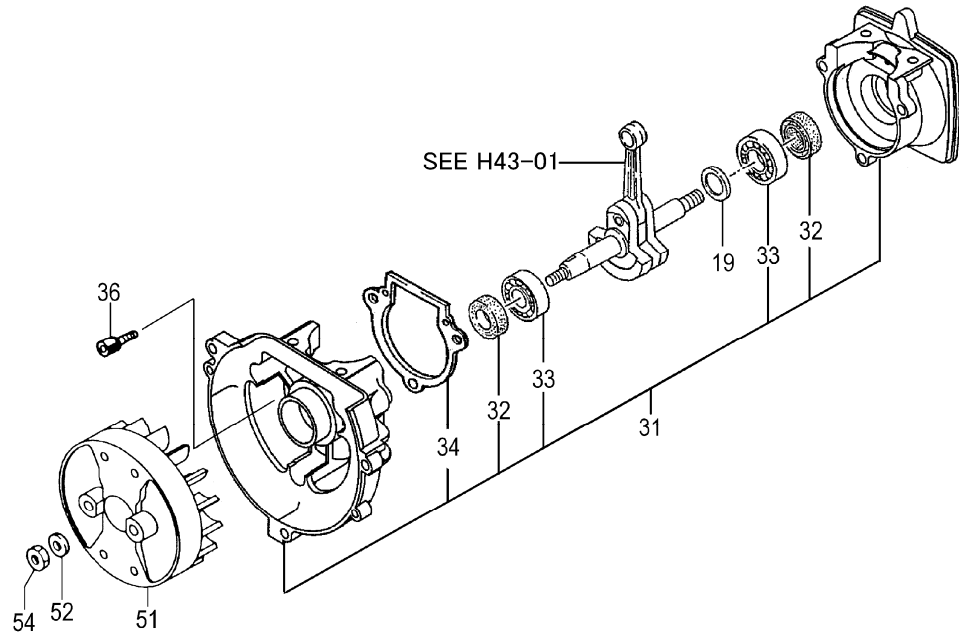

REF. NUMBER	PARTS NUMBER	DESCRIPTION	Q'TY	SERIAL NUMBER
019	330-00200-23	GEAR SHAFT SHIM 0.20	V	
019	330-00200-24	GEAR SHAFT SHIM 0.30	V	
031	072-07120-92	CRANK CASE ASS'Y	1	
032	999-66122-200	OIL SEAL TB 12227	2	
033	999-61600-115	BALL BEARING 6001 C3	2	
034	090-06410-20	CRANK CASE GASKET	1	
036	994-61050-184	HEX. HOLE BOLT 5X18/S	3	
051	155-20550-81	MAGNETO ROTOR COMP.	1	
052	992-01080-011	WASHER 8	1	
054	991-01080-011	HEX. NUT 8	1	

# H43-03 CH55EPA(SM) ENGINE-1

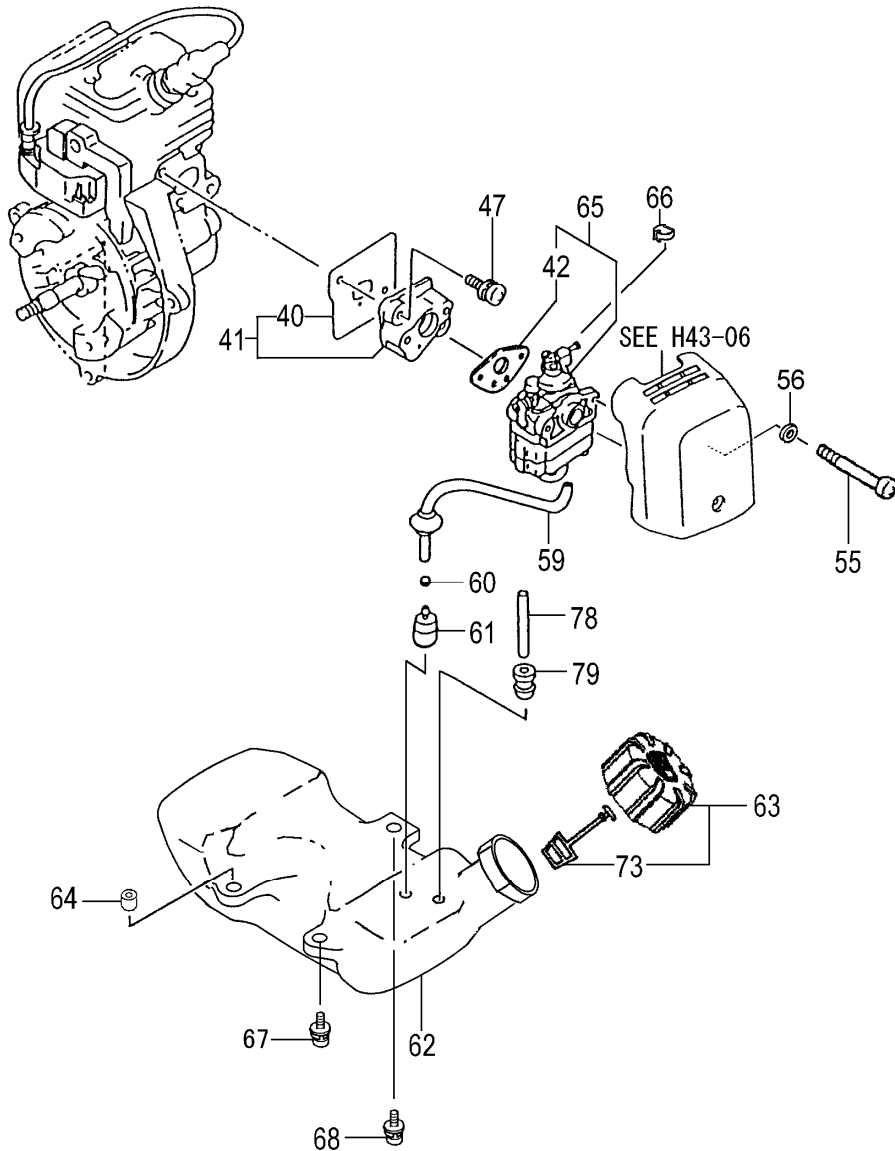

REF. NUMBER	PARTS NUMBER	DESCRIPTION	Q'TY	SERIAL NUMBER
040	403-0631A-20	INLET MANIFOLD GASKET	1	
041	404-0099F-90	CARB INSULATOR SET	1	
042	402-0602K-21	CARBURETOR GASKET	1	
047	994-64050-224	HEX.HOLE BOLT 5X22/WS	2	
055	994-14050-601	SCREW 5X60/S	2	
056	992-01050-011	WASHER 5	2	
059	223-07000-90	SHEILD TUBE	1	
060	680-00731-20	CLIP, 6.3 DIA.	1	
061	675-04042-80	PUMP FILTER BODY COMP	1	
062	591-07135-21	TANK, OR	1	
063	595-01690-90	TANK CAP ASS'Y (BLACK)	1	
064	659-00801-20	COLLAR 5.8	3	
065	455-07139-90	CARBURETOR SET WYL18	1	
066	560-07120-20	SWIVEL CAP	1	
067	994-63050-164	HEX.HOLE BOLT 5X16/PS	2	
068	994-65050-205	SCREW 5X20WS	1	
073	626-32550-20	TANK CAP CHAIN	1	
078	700-03005-08	FUEL PIPE 3X5X85	1	
079	534-32710-20	RETURN GROMMET	1	

# H43-04 CH55EPA(SM) ENGINE-2

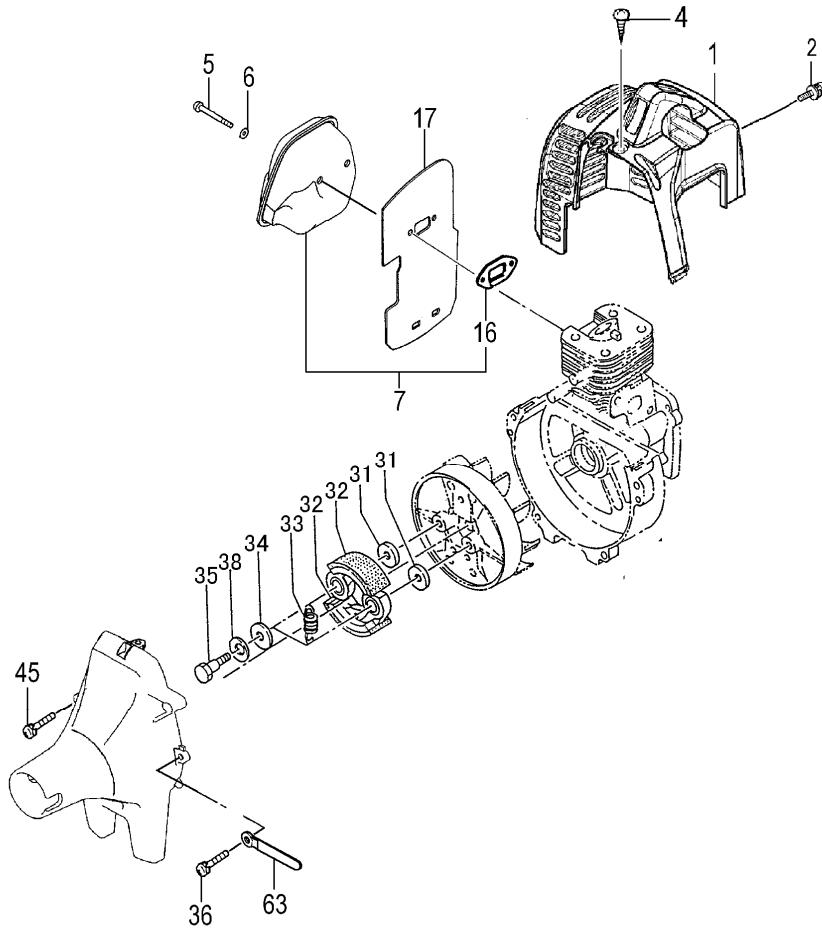

REF. NUMBER	PARTS NUMBER	DESCRIPTION	Q'TY	SERIAL NUMBER
001	738-07162-20	MUFFLER PROTECTOR BL	1	
002	994-15040-151	SCREW 4X15PS	1	
004	990-73045-124	TAPPING SCREW 4.5X12	1	
005	990-51050-503	HEX. HOLE BOLT 5X50	2	
006	992-01050-061	WASHER 5	2	
007	704-07001-90	MUFFLER SET	1	
016	737-07000-20	MUFFLER GASKET	1	
017	133-06540-20	HEAT SHIELD	1	
031	359-02103-20	CLUTCH WASHER B	2	
032	290-06410-80	CLUTCH SHOE COMP.,T-16	2	
033	342-06410-20	CLUTCH SPRING	1	
034	348-06540-20	CLUTCH PLATE A.0.3	2	
035	357-00601-20	STEP BOLT	2	
036	994-64050-184	HEX.HOLE BOLT 5X18/WS	2	
038	992-05080-030	BENT WASHER 8	2	
045	994-64050-304	HEX.HOLE BOLT 5X30/WS	1	
063	198-11600-80	CORD CLAMP COMP.	1	

# H43-05 CH55EPA(SM) RECOIL STARTER

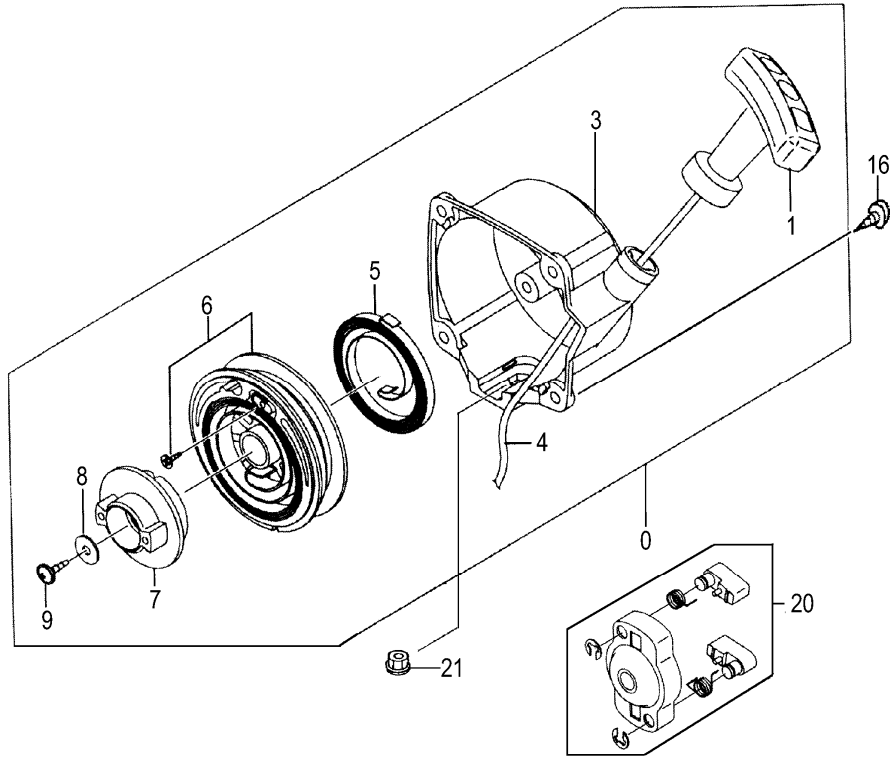

REF. NUMBER	PARTS NUMBER	DESCRIPTION	Q'TY	SERIAL NUMBER
000	762-07130-91	RECOIL STARTER BODY AS	1	
001	785-07085-20	STARTER HANDLE	1	
003	772-07130-81	RECOIL STARTER BODY C	1	
004	783-07130-20	ROPE 2.6X830	1	
005	780-07130-20	RECOIL SPRING	1	
006	778-07130-90	SPRING CASE ASS'Y	1	
007	774-07130-20	STARTER ROPE REEL	1	
008	182-07085-20	SPECIAL WASHER 5.2X15	1	
009	990-72050-144	TAPPING SCREW 5X14	1	
016	994-64040-185	HEX. HOLE BOLT 4X18WS	4	
020	798-07085-90	STARTER PULLEY ASS'Y	1	
021	991-82050-001	FLUNGE NUT 5	1	

**H43-06 CH55EPA(SM) AIR CLEANER**

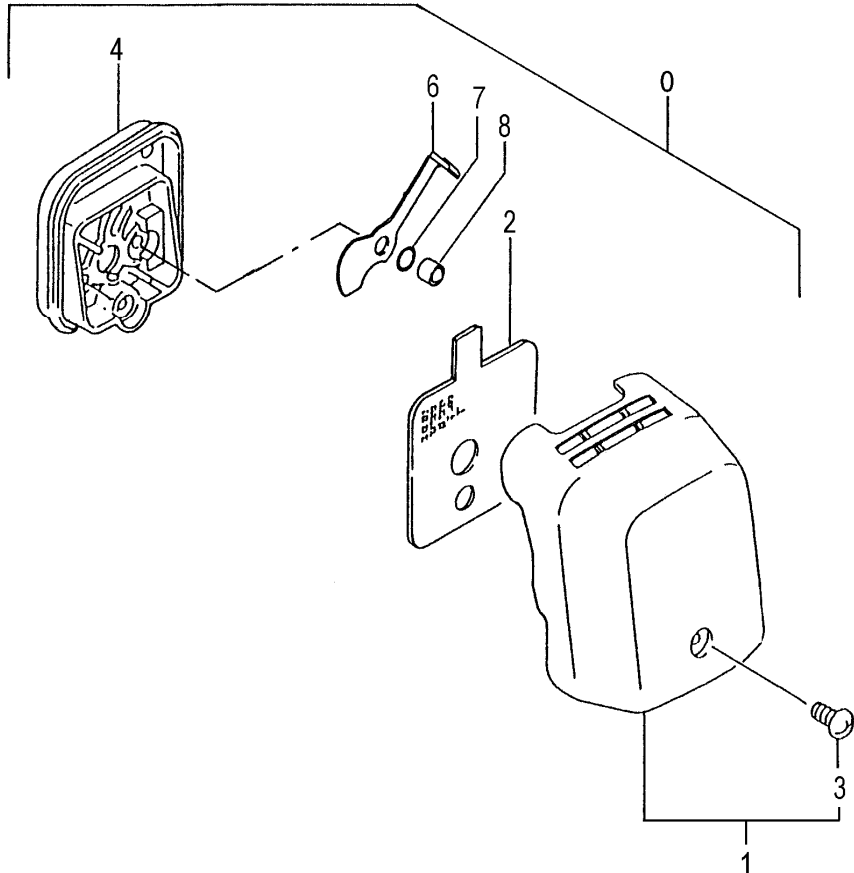

REF. NUMBER	PARTS NUMBER	DESCRIPTION	Q'TY	SERIAL NUMBER
000	410-07142-91	CLEANER ASSY	1	
001	452-00070-92	CLEANER COVER SET	1	
002	421-00070-20	AIRCLEANER ELEMENT	1	
003	380-0637C-20	SPECIAL SCREW	1	
004	423-00070-81	CLEANER BODY COMP.	1	
006	528-07143-80	CHOKE VALVE COMP.	1	
007	992-04080-031	WAVE WASHER 8	1	
008	657-3252A-20	COLLAR 8	1	

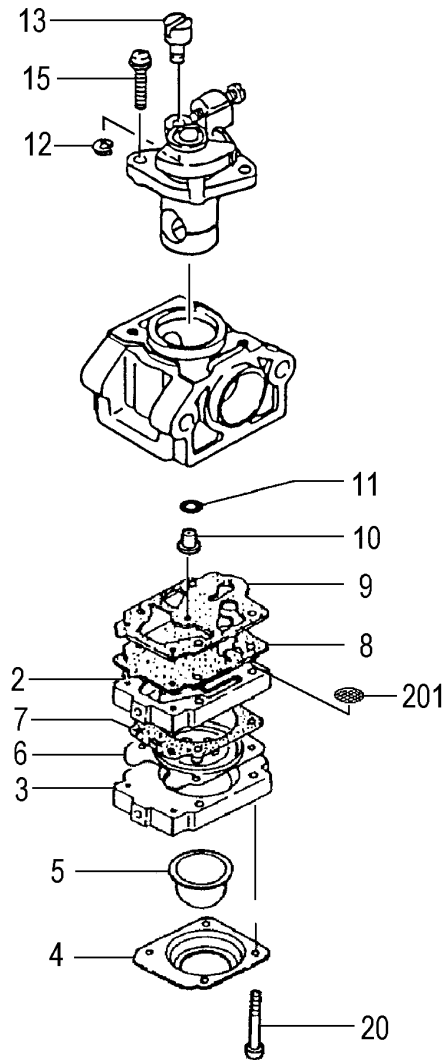
**H43-07****CH55EPA(SM) CARBURETOR**

REF. NUMBER	PARTS NUMBER	DESCRIPTION	Q'TY	SERIAL NUMBER
002	575-25153-80	PUMP BODY COMP	1	
003	442-25151-80	PRIMING PUMP COMP.	1	
004	476-25151-20	DIAPHRAGM COVER	1	
005	447-25108-20	PRIMING BODY	1	
006	474-25241-80	METERING DIAPHRAGM CO	1	
007	475-25153-20	DIAPHRAGM GASKET	1	
008	576-25100-20	PUMP DIAPHRAGM	1	
009	577-25100-20	PUMP GASKET	1	
010	599-2000W-38	MAIN JET #38	1	
011	550-25100-20	O-RING	1	
012	489-25100-20	STOP RING	1	
013	539-25120-20	SWIVEL	1	
015	548-25140-20	THROTTLE SET SCREW	2	
020	548-25151-20	SET SCREW	4	
201	578-25007-20	INLET SCREEN	1	



# H43-08 CH55EPA(SM) FAN CASE

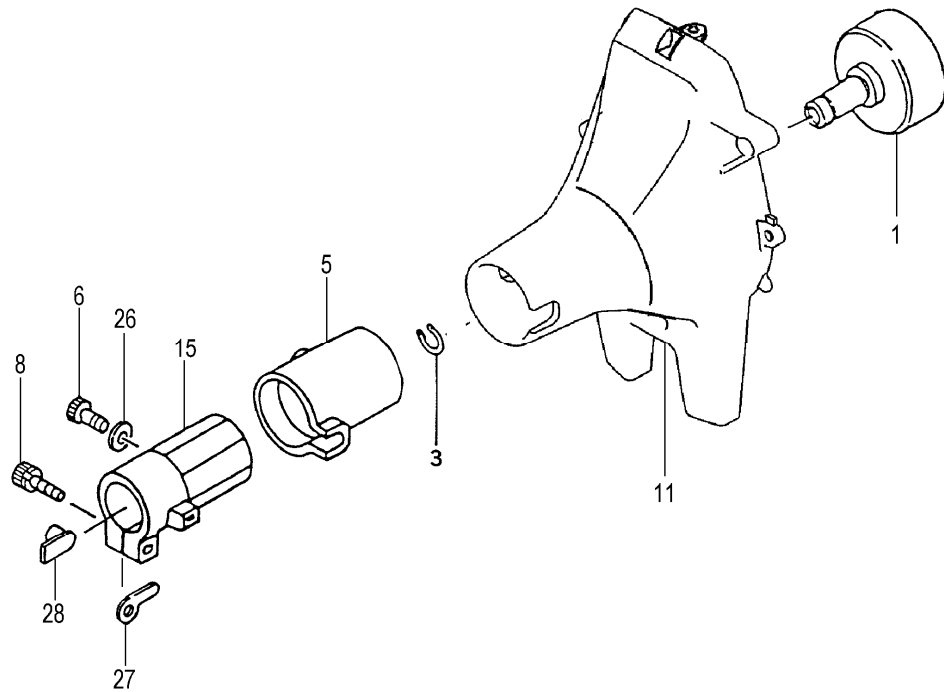

REF. NUMBER	PARTS NUMBER	DESCRIPTION	Q'TY	SERIAL NUMBER
001	289-07060-80	CLUTCH SHAFT COMP.	1	
003	993-50012-002	STOP RING C-12, OUTER	1	
005	599-07120-21	ANTI-VIBE RUBBER	1	
006	990-51050-163	HEX. HOLE BOLT 5X16	1	
008	994-61050-254	HEX. HOLE BOLT 5X25/S	1	
011	112-07124-80	FAN CASE COMP. OR	1	
015	360-00996-20	PIPE HOLDER,24 DIA.	1	
026	992-01050-061	WASHER 5	1	
027	324-37350-20	GEAR CASE WASHER	1	
028	361-00990-20	METAL FITTING	1	



# H43-09 CH55EPA(SM) OPERATION PIPE

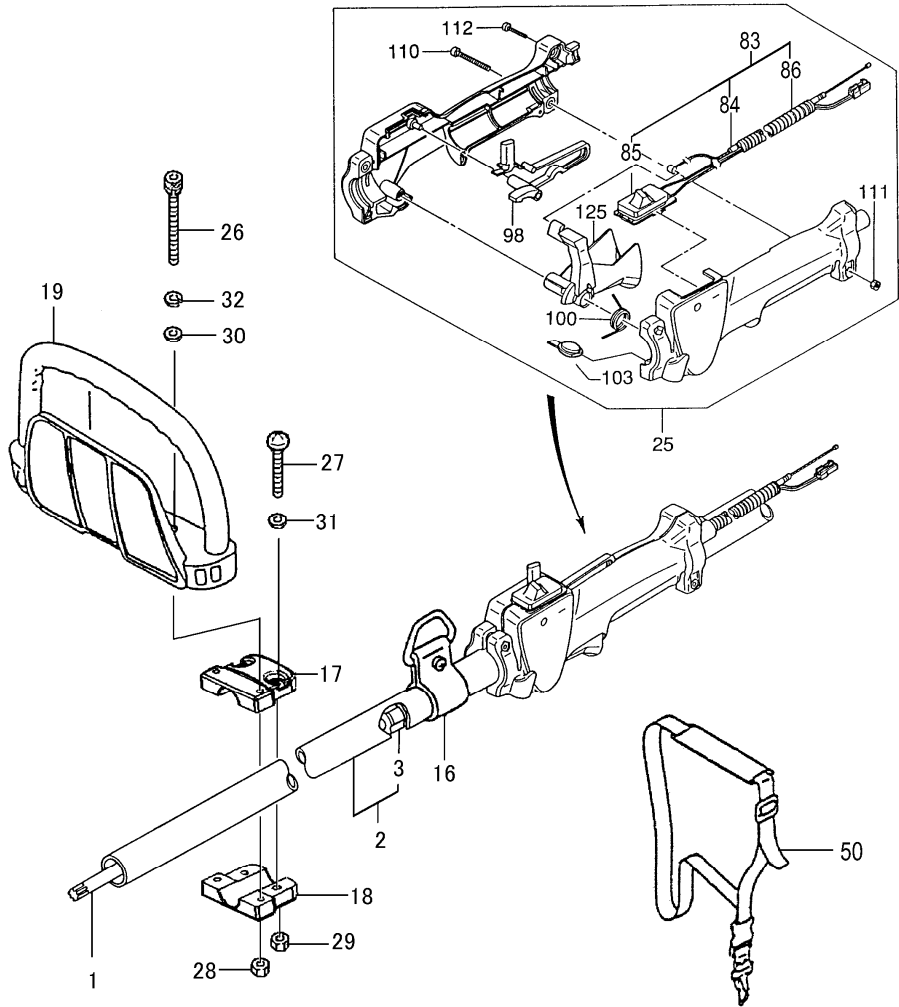

REF. NUMBER	PARTS NUMBER	DESCRIPTION	Q'TY	SERIAL NUMBER
001	343-32243-20	DRIVE SHAFT 633L	1	
002	341-32243-80	DRIVE SHAFT PIPE 600L	1	
003	347-38360-90	BUSH ASS'Y	2	
016	335-37526-90	LIFTING METAL ASS'Y	1	
017	215-32243-20	BRACKET A	1	
018	216-32243-20	BRACKET B	1	
019	210-33160-22	FRONT HANDLE	1	
025	870-38449-90	THROTTLE LEVER ASS'Y	1	
026	990-51050-553	HEX. HOLE BOLT 5X55	2	
027	994-81060-254	HEX. HOLE BUTTON SCREW	2	
028	991-01050-041	NUT 5	2	
029	991-01060-041	HEX. NUT 6	2	
030	992-01050-061	WASHER 5	2	
031	992-01060-061	WASHER 6	2	
032	992-10050-062	S.WASHER 5	2	
050	746-37540-91	SHOULDER BELT ASS'Y	1	
083	885-38449-80	THROTTLE WIRE COMP.	1	
084	887-38449-80	THROTTLE WIRE 4T	1	
085	156-37821-80	STOP BUTTON COMP.	1	
086	164-07014-50	PROTECTION TUBE 7X145L	1	
098	253-38400-20	SAFETY LEVER	1	
100	832-38400-20	RETURN SPRING	1	
103	322-38400-20	BLIND PLUG	1	
110	994-31050-203	SCREW 5X20	2	
111	991-01050-043	CONTAL NUT 5	2	
112	993-46040-202	SCREW 4X20, BLACK	4	
125	880-38400-20	THROTTLE LEVER	1	

**H43-10**

**CH55EPA(SM) GEAR CASE**

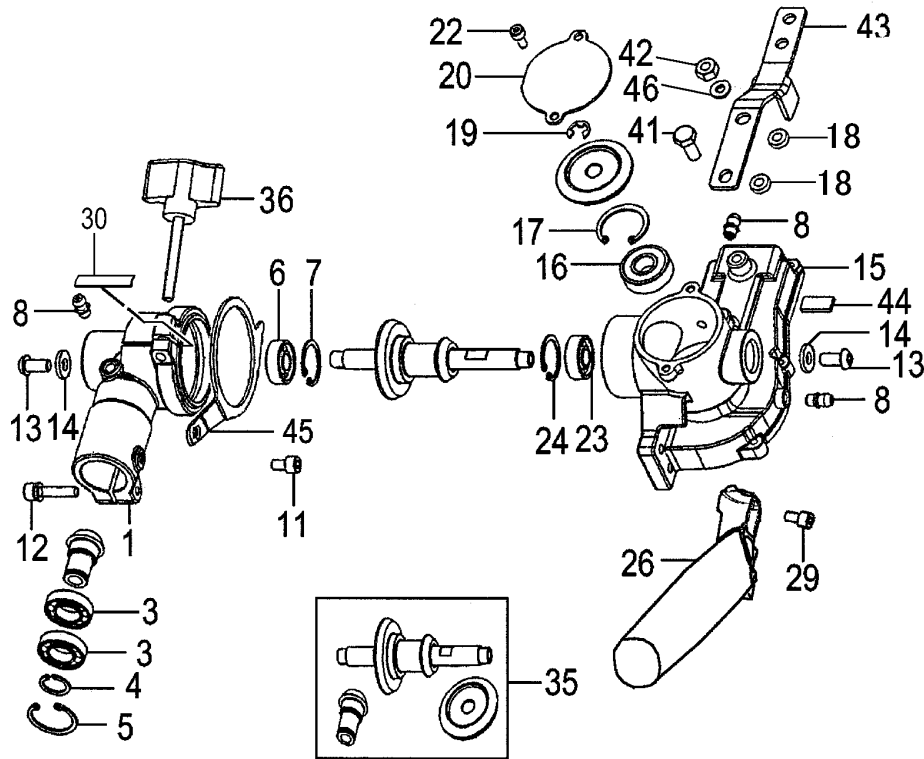

REF. NUMBER	PARTS NUMBER	DESCRIPTION	Q'TY	SERIAL NUMBER
001	300-32287-21	GEAR CASE A,24 DIA	1	
003	999-61690-101	BALL BEARING 6901ZZ, 24M	2	
004	993-52012-002	STOP RING S-12, OUTER	1	
005	993-51024-002	STOP RING C-24, INNER	1	
006	999-61608-013	BALL BEARING 608 ZZ C3	1	
007	993-51022-002	STOP RING C-22, INNER	1	
008	300-32250-80	GREASE NIPPLE COMP.	3	
011	990-51050-103	HEX. HOLE BOLT 5X10	1	
012	994-61050-254	HEX. HOLE BOLT 5X25/S	1	
013	990-53060-125	HEX. HOLE BOLT 6X12	2	
014	871-32600-20	SPECIAL WASHER B	2	
015	301-32286-21	GEAR CASE B	1	
016	999-61600-014	BALL BEARING #6000 2RS	1	
017	993-51026-002	STOP RING C-26, INNER	1	
018	871-32600-20	SPECIAL WASHER B	2	
019	993-55060-000	STOP RING E-6	1	
020	327-32280-20	GEAR CASE COVER A	1	
022	990-51040-085	HEX HOLE BOLT 4X8	2	
023	999-61608-013	BALL BEARING 608 ZZ C3	1	
024	993-51022-002	STOP RING C-22, INNER	1	
026	210-32286-20	HANDLE	1	
029	990-53060-153	HEX HOLE BUTTON SCREW	2	
030	088-32287-20	GREASE SEALED	1	
035	302-32286-01	GEAR SET	1	
036	512-32286-80	HANDLE KNOB A COMP.	1	
041	990-23060-141	PLUS BOLT 6X14	1	
042	991-87060-001	NUT 6 UPS-P	1	
043	462-32286-20	SUPPORT PLATE	1	
044	086-32286-20	GREASE SEAL B	1	
045	222-32286-20	ANGLE LIMITTER	1	
046	992-01060-011	WASHER 6	1	

# H43-11 CH55EPA(SM) BLADE

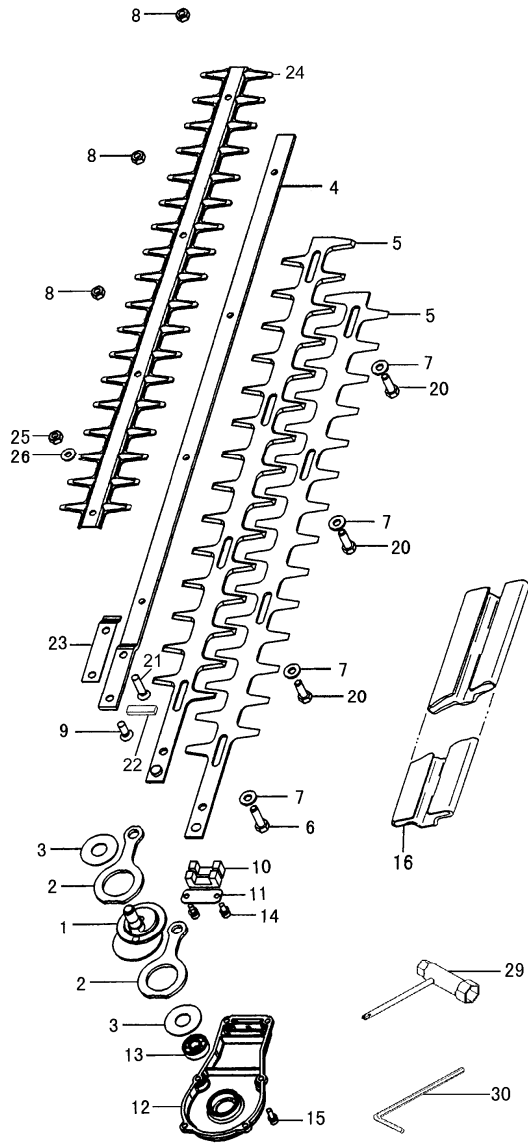

REF. NUMBER	PARTS NUMBER	DESCRIPTION	Q'TY	SERIAL NUMBER
001	100-32282-81	CAM SHAFT COMP.	1	
002	101-33160-22	CAM ROD	2	
003	075-32280-20	CAM-ROD GUIDE PLATE	2	
004	122-32286-21	CUTTER GUIDE 625.5MM	1	
005	120-32287-21	CUTTER A	2	
006	124-32287-20	FIXING BOLT A M6	1	
007	129-33202-20	WASHER 7 BLACK	4	
008	991-82060-001	FLANGE NUT 6	3	
009	990-52060-165	HEX HOLE FLUSH SCREW	1	
010	085-32286-20	GREASE SEAL A	2	
011	105-32280-20	CAM-ROD HOLDING PLATE	1	
012	328-32286-21	GEAR CASE COVER B	1	
013	999-61608-013	BALL BEARING 608 ZZ C3	1	
014	994-61040-104	HEX. HOLE BOLT 4X10S	2	
015	994-61040-124	HEX. HOLE BOLT 4X12S	6	
016	138-33168-20	CUTTER COVER	1	
020	125-32287-20	CUTTER FIXING BOLT B	3	
021	990-52060-255	HEX. HOLE FLUSH BOLT 6X	1	
022	087-32286-20	GREASE SEAL B	1	
023	296-32286-20	SPACER	1	
024	136-32286-20	PROTECTION PLATE	1	
025	991-87060-001	NUT 6 UPS-P	1	
026	992-01060-011	WASHER 6	1	
029	036-29331-50	COMBI. BOX SPANNER 10X	1	
030	813-20000-20	HEX. WRENCH 4	1	

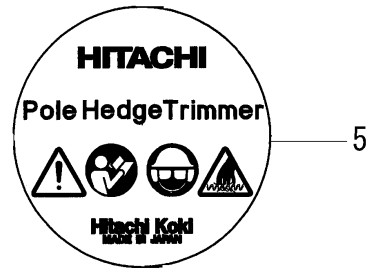
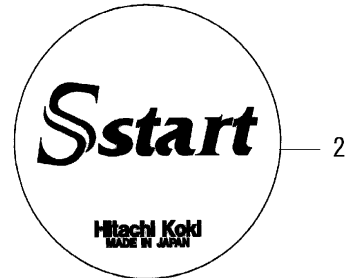
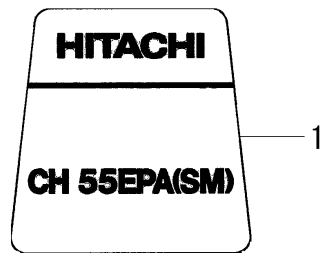
**H43-11****CH55EPA(SM) LABELS**

REF. NUMBER	PARTS NUMBER	DESCRIPTION	Q'TY	SERIAL NUMBER
001	929-51300-20	SMBOL MARK CH55EPA(SM)	1	
002	915-07182-21	STARTER MARK	1	
005	919-73800-20	CAUTION MARK HITACHI	1	