

**H39-01**

**CH66EB(ST) CYLINDER/PISTON/CRANK SFAHT**

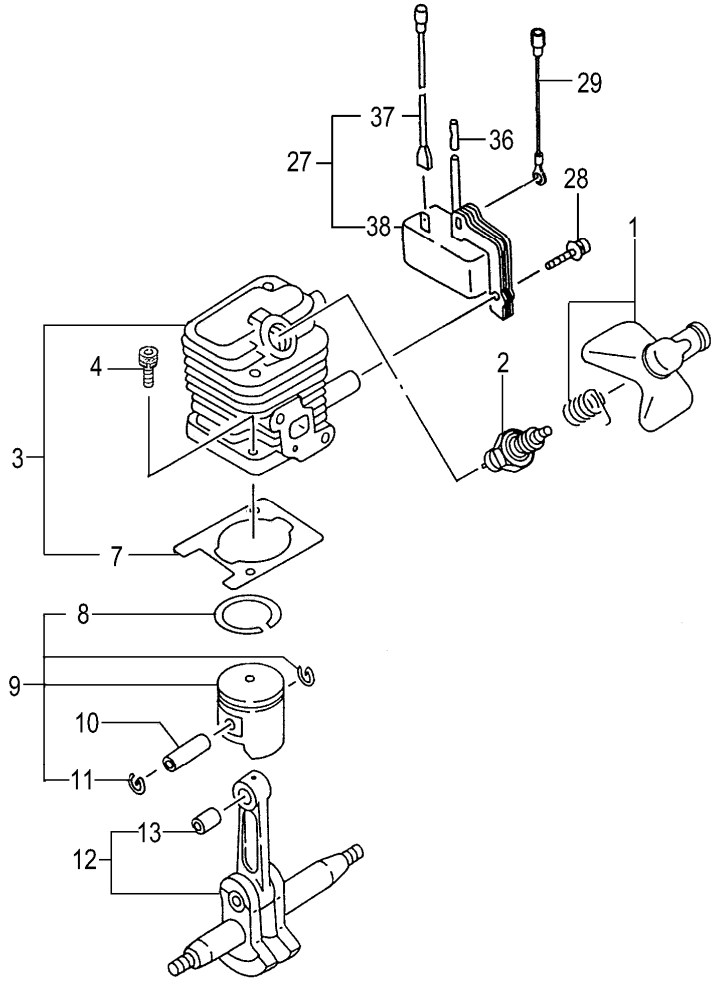

REF. NUMBER	PARTS NUMBER	DESCRIPTION	Q'TY	SERIAL NUMBER
001	157-06500-91	SPARK PLUG CAP ASS'Y	1	
002	018-00555-20	SPARK PLUG, RCJ8Y	1	
003	001-0650A-90	CYLINDER SET	1	
004	994-61050-184	HEX. HOLE BOLT 5X18/S	2	
007	017-06500-20	CYLINDER GASKET	1	
008	041-00601-21	PISTON RING	1	
009	030-0650A-90	PISTON SET	1	
010	037-06500-20	PISTON PIN	1	
011	039-01620-20	PISTON PIN CIRCLIP	2	
012	046-06500-80	CRANK SHAFT COMP.	1	
013	999-62081-225	NEEDLE BRG F-810 1.4X8.5	1	
027	153-21532-90	IGNITION COIL ASS'Y	1	
028	994-64040-184	HEX. HOLE BOLT 4X18WS	2	
029	274-0700D-80	CORD, B130M	1	
036	250-06500-20	INSULATOR TUBE, 50L	1	
037	178-06500-80	CORD	1	
038	167-21532-80	IGNITION COIL COMP.	1	

**H39-02**

**CH66EB(ST) CRANK CASE**

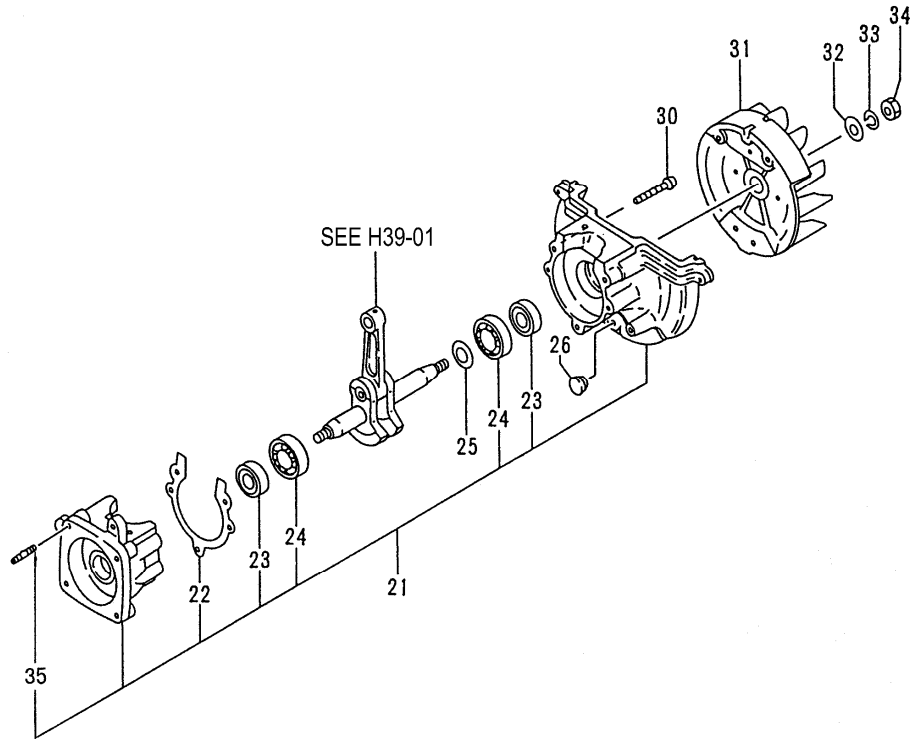

REF. NUMBER	PARTS NUMBER	DESCRIPTION	Q'TY	SERIAL NUMBER
021	072-06500-90	CRANK CASE ASS'Y	1	
022	090-06500-20	CRANKCASE GASKET	1	
023	999-66122-200	OIL SEAL TB 12227	2	
024	999-61600-115	BALL BEARING 6001 C3	2	
025	330-00200-23	GEAR SHAFT SHIM 0.20	V	
025	330-00200-24	GEAR SHAFT SHIM 0.30	V	
026	599-00601-20	ANTI-VIBE RUBBER	1	
030	994-61050-304	HEX. HOLE BOLT 5X30S	3	
031	155-21523-80	MAGNETO ROTOR COMP.	1	
032	992-01080-011	WASHER 8	1	
033	992-10080-012	S.WASHER 8	1	
034	991-01080-011	HEX. NUT 8	1	
035	100-02100-20	STUD BOLT 6X22	2	

**H39-03**

**CH66EB(ST) ENGINE-1**

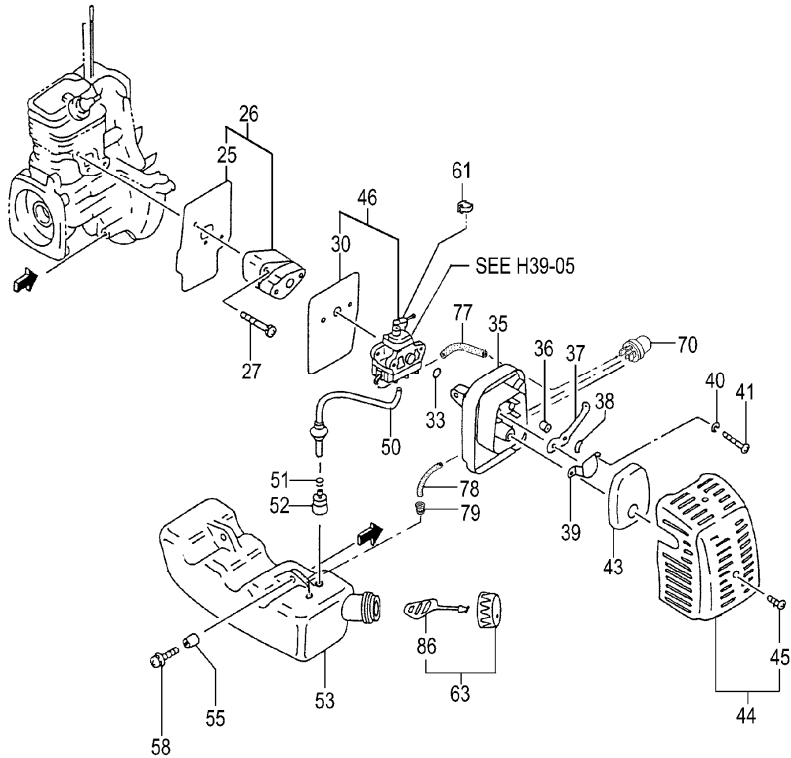

REF. NUMBER	PARTS NUMBER	DESCRIPTION	Q'TY	SERIAL NUMBER
025	403-06500-20	INTAKE PIPE GASKET	1	
026	404-06500-90	CARB. INSULATOR SET, SP	1	
027	994-64050-254	HEX. HOLE BOLT 5X25WS	2	
030	402-06500-20	CARBURETOR GASKET	1	
033	999-67015-000	O-RING P-15	1	
035	423-06500-81	CLEANER BODY COMP.	1	
036	470-06500-20	COLLAR 7.5	2	
037	528-0650T-20	CHOKE VALVE	1	
038	992-04080-031	WAVE WASHER 8	1	
039	476-01700-20	BLOW OVER CHECK BOAR	1	
040	992-10050-012	S.WASHER 5	2	
041	990-11050-602	SCREW 5X60	2	
043	446-06500-21	CLEANER SPONGE	1	
044	452-06500-91	CLEANER COVER ASS'Y	1	
045	380-0637C-20	SPECIAL SCREW	1	
046	455-0651A-90	CARBURETOR SET, WYL12	1	
050	223-06500-90	FUEL PIPE ASS'Y L=130	1	
051	680-00731-20	CLIP, 6.3 DIA.	1	
052	675-04042-80	PUMP FILTER BODY COMP	1	
053	591-06504-22	FUEL TANK	1	
055	659-00801-20	COLLAR 5.8	2	
058	994-63050-185	HEX. HOLE BOLT 5X18PS	2	
061	560-07120-20	SWIVEL CAP	1	
063	595-00093-90	TANK CAP D ASS'Y. ORANG	1	
070	442-25143-80	PRIMING PUMP COMP.	1	
077	700-02504-08	FUEL PIPE 2.5X4X80	1	
078	700-02504-07	FUEL PIPE 2.5X4X70	1	
079	534-32710-20	RETURN GROMMET	1	
086	626-32550-20	TANK CAP CHAIN	1	

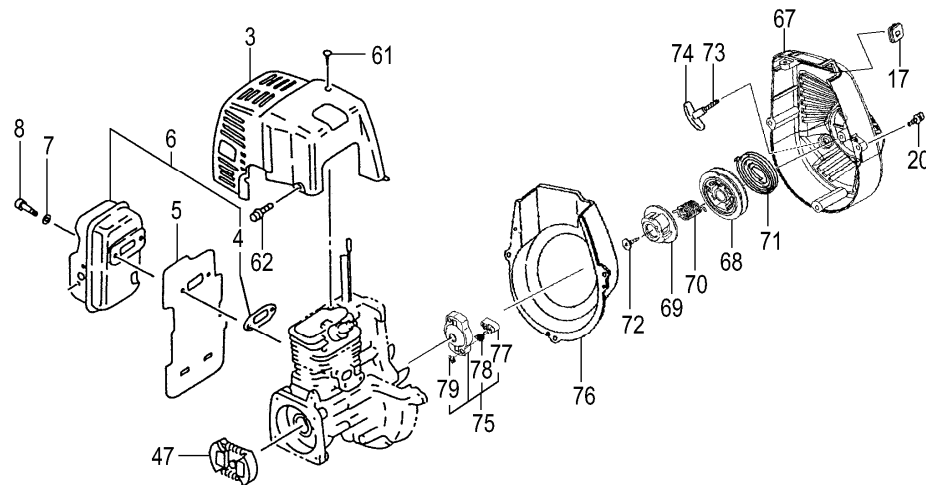
**H39-04****CH66EB(ST) ENGINE-2**

REF. NUMBER	PARTS NUMBER	DESCRIPTION	Q'TY	SERIAL NUMBER
003	738-06500-20	MUFFLER PROTECTOR	1	
004	737-06500-20	MUFFLER GASKET	1	
005	133-06500-20	HEAT SHIELD	1	
006	704-06504-91	MUFFLER SET	1	
007	992-01050-011	WASHER 5	2	
008	990-51050-503	HEX. HOLE BOLT 5X50	2	
017	203-0604A-20	GROMMET	1	
020	994-63040-184	HEX.HOLE BOLT 4X18PS	3	
047	277-0634F-91	CLUTCH ASS'Y	1	
061	990-72045-164	TAPPING SCREW 4.5X16	1	
062	994-25040-128	BOLT 4X12PS	2	
067	112-0651H-80	FAN CASE COMP.	1	
068	774-0651H-20	STARTER ROPE REEL	1	
069	759-0651H-20	CAM PLATE	1	
070	758-0651H-20	DUMPER SPRING	1	
071	780-06097-20	RECOIL SPRING	1	
072	839-03045-20	SET SCREW	1	
073	783-0651H-20	ROPE 3X890	1	
074	785-06410-20	STARTER HANDLE	1	
075	798-0651H-90	STARTER PULLEY ASS'Y	1	
076	132-06602-20	DEFLECTOR	1	
077	788-0651H-20	STARTER PAWL	2	
078	790-06097-20	STARTER PAWL SPRING	2	
079	993-55050-000	STOP RING E-5	2	

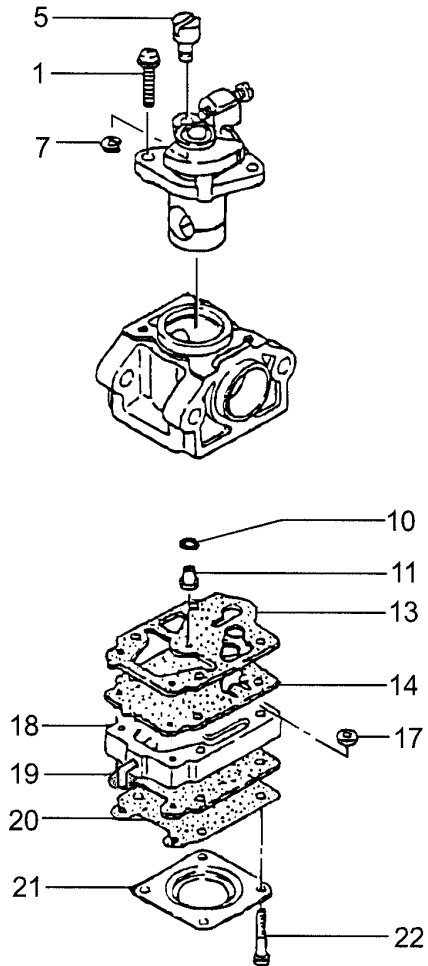
**H39-05****CH66EB(ST) CARBURETOR**

REF. NUMBER	PARTS NUMBER	DESCRIPTION	Q'TY	SERIAL NUMBER
001	548-25140-20	THROTTLE SET SCREW	2	
005	539-25120-20	SWIVEL	1	
007	489-25100-20	STOP RING	1	
010	550-25100-20	O-RING	1	
011	599-200BW-34	MAIN JET #34.5	1	
013	577-25100-20	PUMP GASKET	1	
014	576-25100-20	PUMP DIAPHRAGM	1	
017	578-25007-20	INLET SCREEN	1	
018	575-25147-80	PUMP BODY COMP.	1	
019	475-25038-20	DIAPHRAGM GASKET	1	
020	474-25001-80	METERING DIAPHRAGM CO	1	
021	476-25004-20	DIAPHRAGM COVER	1	
022	548-25101-20	SET SCREW	4	

**H39-06**

**CH66EB(ST) FRONT HANDLE**

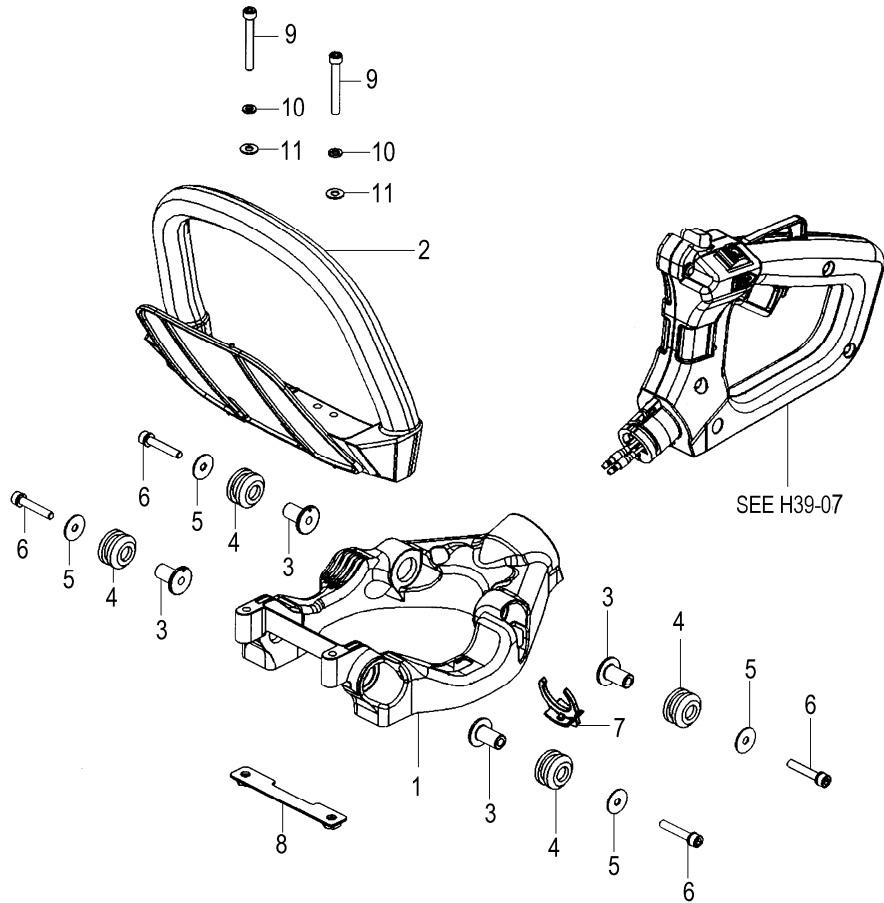

REF. NUMBER	PARTS NUMBER	DESCRIPTION	Q'TY	SERIAL NUMBER
001	260-33290-20	FLAME	1	
002	210-33160-22	FRONT HANDLE	1	
003	276-32710-20	DAMPER COLLAR B	4	
004	266-32750-20	DAMPER B	4	
005	368-32057-20	BRAKE SHAFT WASHER	4	
006	994-61050-304	HEX. HOLE BOLT 5X30S	4	
007	505-33196-20	CLIP BLK	1	
008	040-33160-80	HANDLE SUPPORT COMP.	1	
009	990-51050-403	HEX. HOLE BOLT 5X40	2	
010	992-10050-062	S.WASHER 5	2	
011	992-01050-061	WASHER 5	2	

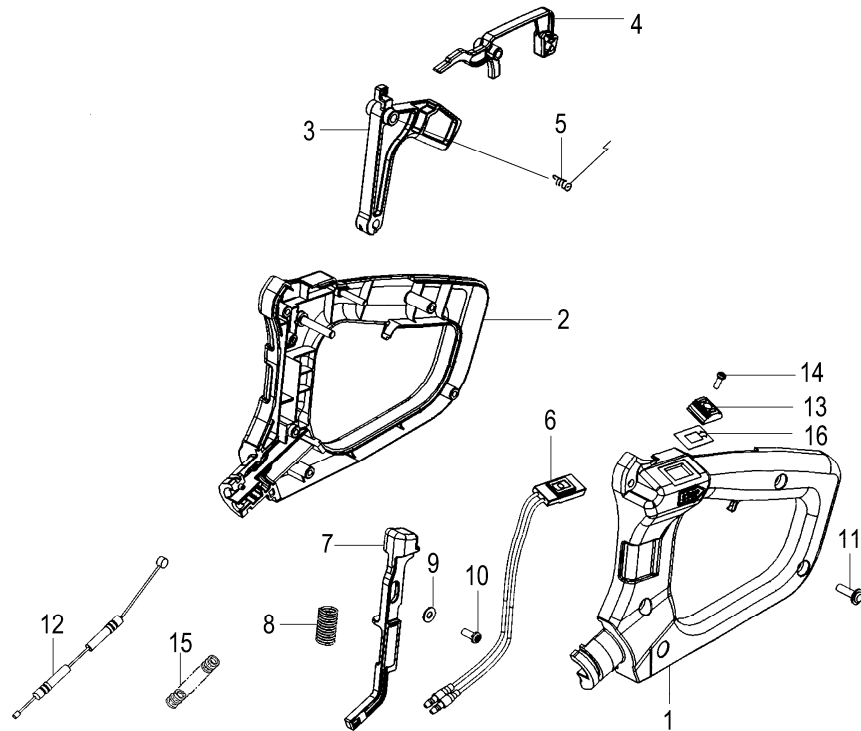
**H39-07****CH66EB(ST) REAR HANDLE**

REF. NUMBER	PARTS NUMBER	DESCRIPTION	Q'TY	SERIAL NUMBER
001	051-33290-20	HANDLE B	1	
002	050-33290-20	HANDLE A	1	
003	230-33290-20	THROTTLE LEVER	1	
004	231-33290-20	SAFETY LEVER	1	
005	232-33160-20	THROTTLE LEVER SPRING	1	
006	170-33290-80	STOP BUTTON COMP.	1	
007	233-33290-20	LOCK LEVER	1	
008	245-33290-20	SPRING	1	
009	992-01040-011	WASHER 4	1	
010	993-41040-101	SCREW 4X10	1	
011	990-72045-164	TAPPING SCREW 4.5X16	5	
012	885-33290-80	THROTTLE WIRE COMP.	1	
013	258-11650-20	BUTTON STOP	1	
014	994-31030-101	SCREW 3X10	1	
015	164-07015-01	PROTECTION TUBE 150L	1	
016	925-33160-20	STOP BUTTON MARK	1	

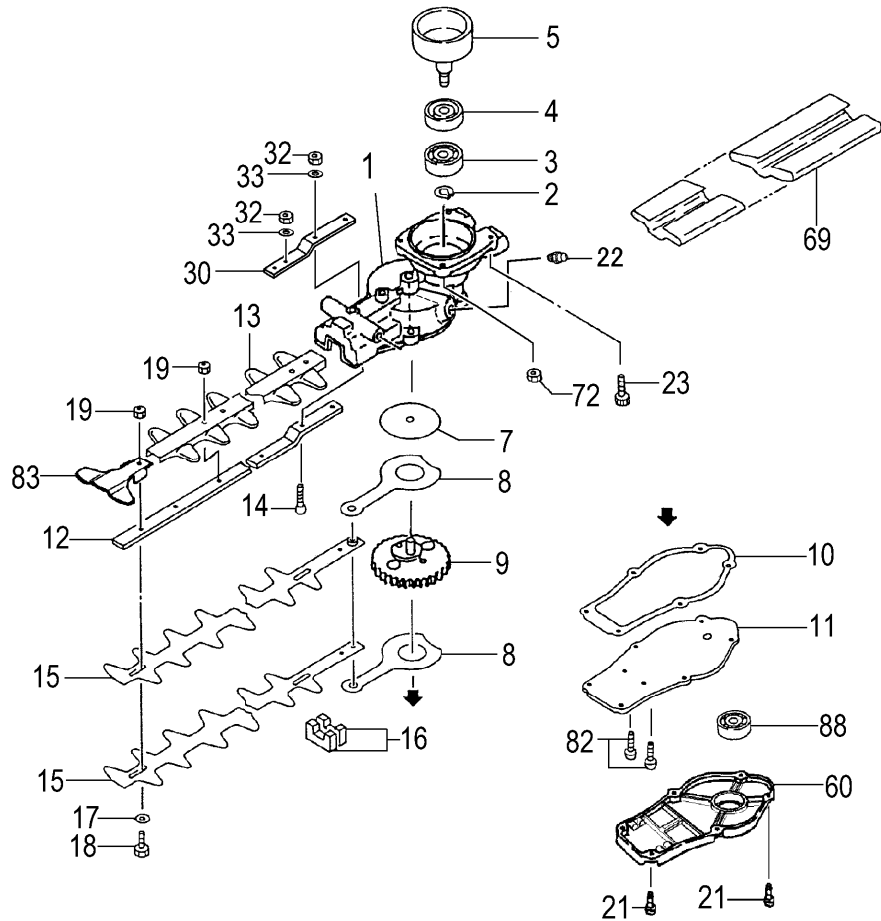
**H39-08****CH66EB(ST) GEAR CASE/BLADE**

REF. NUMBER	PARTS NUMBER	DESCRIPTION	Q'TY	SERIAL NUMBER
001	300-33290-81	GEAR CASE COMP.	1	
002	993-50015-002	STOP RING C-15, OUTER	1	
003	999-61600-200	BALL BEARING #6002, 32MM	1	
004	999-61600-202	BALL BEARING #6002Z, 32MM	1	
005	288-33180-80	CLUTCH DRUM COMP.	1	
007	075-33160-20	GUIDE PLATE	1	
008	101-33190-20	CAM ROD	2	
009	292-33194-80	GEAR 2 COMP.	1	
010	303-33160-20	GEAR CASE GASKET	1	
011	630-33165-20	GEAR CASE COVER	1	
012	122-33248-20	CUTTER GUIDE 734L M6	1	
013	136-33160-20	PROTECTION PLATE	1	
014	990-52060-255	HEX. HOLE FLUSH BOLT 6X	2	
015	120-33168-21	CUTTER A	2	
016	085-33160-20	GREASE SEAL A	2	
017	129-33202-20	WASHER 7 BLACK	5	
018	124-32287-20	FIXING BOLT A M6	5	
019	991-82060-001	FLANGE NUT 6	4	
021	994-61040-124	HEX. HOLE BOLT 4X12S	6	
022	300-32250-80	GREASE NIPPLE COMP.	1	
023	994-61060-184	HEX. HOLE BOLT 6X18/S	2	
030	462-33290-20	SUPPORT PLATE	1	
032	991-87060-001	NUT 6 UPS-P	3	
033	992-01060-011	WASHER 6	3	
060	301-33160-21	GEAR CASE B	1	
069	138-33171-20	CUTTER COVER	1	
072	994-40060-011	SPRING NUT 6	2	
082	994-61040-104	HEX. HOLE BOLT 4X10S	2	
083	135-33191-20	GUARD PLATE	1	
088	999-61608-013	BALL BEARING 608 ZZ C3	1	



**H39-09**

**CH66EB(ST) TOOLS**

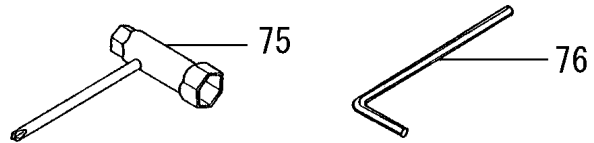

REF. NUMBER	PARTS NUMBER	DESCRIPTION	Q'TY	SERIAL NUMBER
075	036-29331-50	COMBI. BOX SPANNER 10X	1	
076	813-20000-20	HEX. WRENCH 4	1	

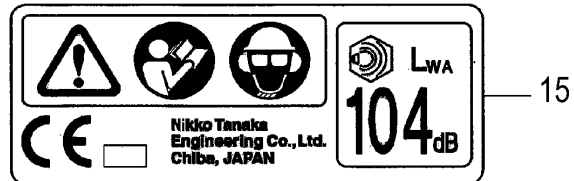
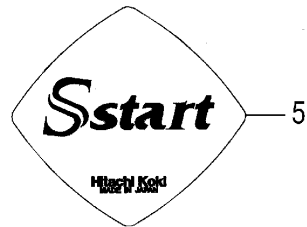
**H39-10****CH66EB(ST) LABELS**

REF. NUMBER	PARTS NUMBER	DESCRIPTION	Q'TY	SERIAL NUMBER
001	906-51700-21	NAME PLATE CH66EB(ST)	1	
005	915-51700-21	STARTER MARK S-START	1	
015	919-06620-22	CAUTION MARK A	1	