

ELECTRIC TOOL PARTS LIST

CORDLESS ROTARY HAMMER 2007 · 6 · 25 Model DH 25DL (E1)

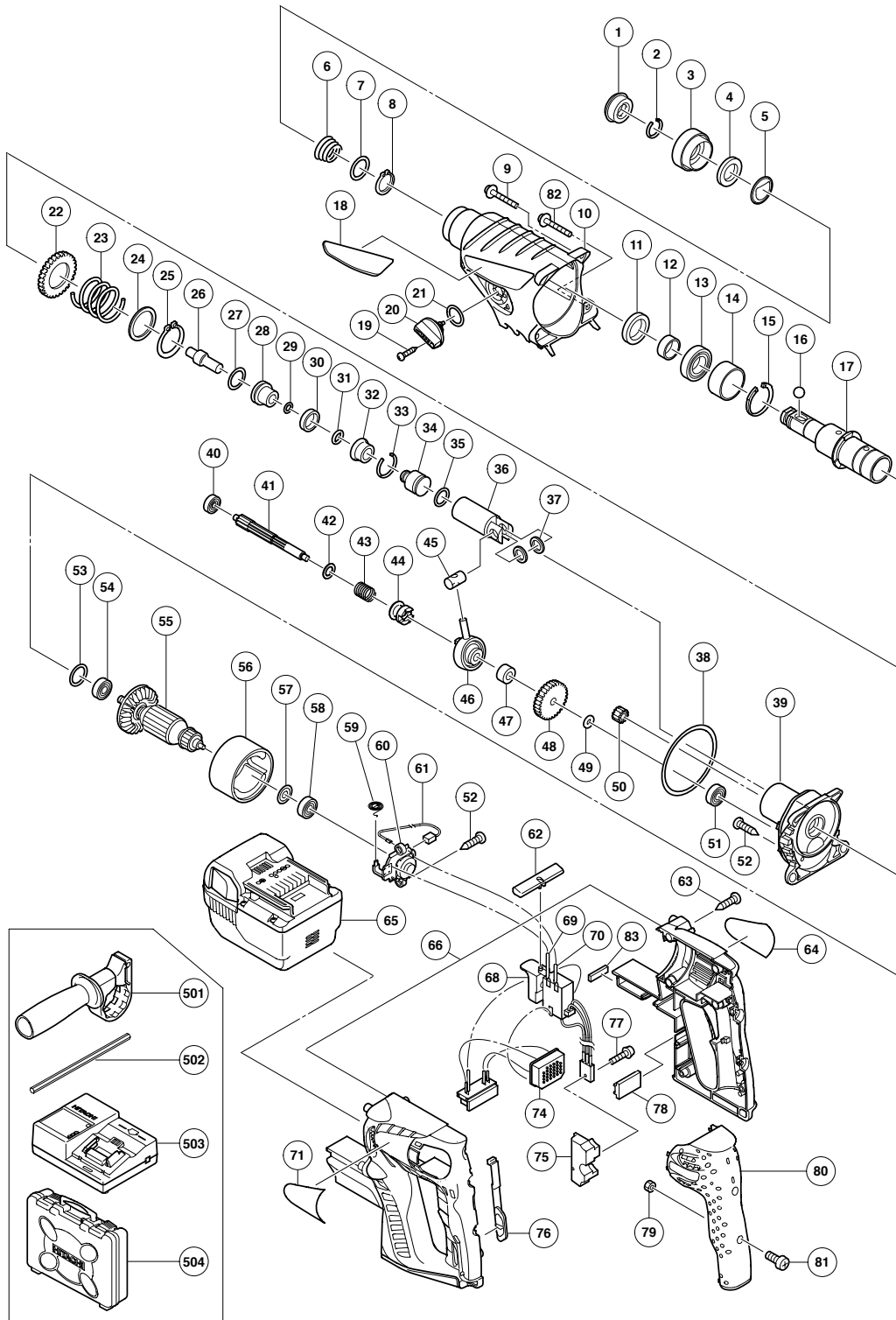

PARTS

DH 25DL

ITEM NO.	CODE NO.	DESCRIPTION	NO. USED	REMARKS
1	306-345	FRONT CAP	1	
2	306-340	STOPPER RING	1	
3	323-154	GRIP	1	
4	324-528	BALL HOLDER	1	
5	324-526	HOLDER PLATE	1	
6	322-812	HOLDER SPRING	1	
7	984-118	WASHER (B)	1	
8	939-547	RETAINING RING FOR D20 SHAFT (10 PCS.)	1	
9	305-558	TAPPING SCREW (W/FLANGE) D5X25 (BLACK)	2	
10	323-167	GEAR COVER	1	
11	307-688	OIL SEAL	1	
12	322-815	SLEEVE	1	
13	690-4DD	BALL BEARING 6904DDPS2L	1	
14	324-522	SLEEVE (A)	1	
15	322-813	RETAINING RING 37MM	1	
16	959-156	STEEL BALL D7.0 (10 PCS.)	1	
17	322-814	CYLINDER	1	
18	323-172	HITACHI PLATE (GREEN)	1	
19	323-239	TAPPING SCREW D2.6X10	1	
20	323-161	CHANGE LEVER	1	
21	878-885	O-RING (S-18)	1	
22	301-677	SECOND GEAR	1	
23	316-135	SPRING (A)	1	
24	301-679	WASHER (A)	1	
25	948-310	RETAINING RING FOR D30 SHAFT	1	
26	324-525	SECOND HAMMER	1	
27	944-486	O-RING (1AP-20)	1	
28	324-523	HAMMER HOLDER	1	
29	322-802	O-RING (B)	1	
30	322-805	DAMPER (A)	1	
31	322-808	O-RING (C)	1	
32	324-524	DAMPER HOLDER	1	
33	322-807	STOPPER RING	1	
34	324-535	STRIKER	1	
35	322-834	O-RING (I.D. 16)	1	
36	324-534	PISTON	1	
37	322-799	WASHER (C)	2	
38	325-254	O-RING (I.D. 72)	1	
39	323-157	INNER COVER ASS'Y	1	INCLUD. 51
40	626-VVM	BALL BEARING 626VVC2PS2L	1	
41	323-151	SECOND SHAFT	1	
42	301-659	WASHER (B)	1	
43	301-660	CLUTCH SPRING	1	
44	324-532	CLUTCH	1	
45	322-798	PISTON PIN	1	
46	324-533	RECIPROCATING BEARING	1	
47	323-152	COLLAR	1	
48	323-153	FIRST GEAR	1	
49	301-663	SPACER	1	
50	323-170	PINION	1	
51	626-VVM	BALL BEARING 626VVC2PS2L	1	

STANDARD ACCESSORIES

DH 25DL

ITEM NO.	CODE NO.	DESCRIPTION	NO. USED	REMARKS
501	323-155	SIDE HANDLE	1	
502	303-709	DEPTH GAUGE	1	
503		CHARGER (MODEL UC 36YRL)	1	
504	323-350	CASE	1	

OPTIONAL ACCESSORIES

ITEM NO.	CODE NO.	DESCRIPTION	NO. USED	REMARKS
601	303-332	HAMMER DRILL CHUCK SET 13MM	1	INCLUD. 602, 603
602	303-334	CHUCK HANDLE	1	
603	303-335	RUBBER CAP	1	
604	321-825	DRILL CHUCK AND ADAPTER SET	1	INCLUD. 605, 606
605	303-623	CHUCK ADAPTER (G) (SDS PLUS)	1	
606	321-814	DRILL CHUCK 13VLRB-D	1	INCLUD. 607, 608
607	995-344	FLAT HD. SCREW (A) (LEFT HAND) M6X25	1	
608	987-576	CHUCK WRENCH FOR 13VLB-D, 13VLR-D	1	
609	321-813	DRILL CHUCK 13VLD-D	1	INCLUD. 610
610	303-334	CHUCK HANDLE	1	
611	971-787	DUST CUP	1	
612	931-844	STOPPER	1	
613	971-511Z	+ DRIVER BIT (A) NO. 2 25L	1	
614	971-512Z	+ DRIVER BIT (A) NO. 3 25L	1	
615	971-794	ANCHOR SETTING ADAPTER A W1/4" (MANUAL)	1	
616	971-795	ANCHOR SETTING ADAPTER A W5/16" (MANUAL)	1	
617	971-796	ANCHOR SETTING ADAPTER A W3/8" (MANUAL)	1	
618	971-797	ANCHOR SETTING ADAPTER A W1/2" (MANUAL)	1	
619	971-798	ANCHOR SETTING ADAPTER A W5/8" (MANUAL)	1	
620	971-799	ANCHOR SETTING ADAPTER B W1/4" (MANUAL)	1	
621	971-800	ANCHOR SETTING ADAPTER B W5/16" (MANUAL)	1	
622	971-801	ANCHOR SETTING ADAPTER B W3/8" (MANUAL)	1	
623	971-802	ANCHOR SETTING ADAPTER B W1/2" (MANUAL)	1	
624	971-803	ANCHOR SETTING ADAPTER B W5/8" (MANUAL)	1	
625	944-477	COTTER	1	
626	303-617	TAPER SHANK ADAPTER (SDS PLUS) NO. 1	1	
627	303-619	A-TAPER SHANK ADAPTER (SDS PLUS)	1	
628	303-620	B-TAPER SHANK ADAPTER (SDS PLUS)	1	
629	303-624	CHUCK ADAPTER (D) (SDS PLUS)	1	
630	302-976	ANCHOR SETTING ADAPTER A (SDS+) W1/4X260L	1	
631	302-975	ANCHOR SETTING ADAPTER A (SDS+) W5/16X260L	1	
632	303-621	ANCHOR SETTING ADAPTER A (SDS+) W3/8X160L	1	
633	302-974	ANCHOR SETTING ADAPTER A (SDS+) W3/8X260L	1	
634	302-979	ANCHOR SETTING ADAPTER B (SDS+) W1/4X260L	1	
635	302-978	ANCHOR SETTING ADAPTER B (SDS+) W5/16X260L	1	
636	303-622	ANCHOR SETTING ADAPTER B (SDS+) W3/8X160L	1	
637	302-977	ANCHOR SETTING ADAPTER B (SDS+) W3/8X260L	1	
638	303-044	CHEMICAL ANCHOR ADAPTER (SDS+) 12.7MMX90L	1	
639	303-045	CHEMICAL ANCHOR ADAPTER (SDS+) 19.0MMX100L	1	
640	303-625	CORE BIT SHANK (SDS PLUS) 25-38MM 105L	1	
641	303-626	CORE BIT SHANK (SDS PLUS) 25-38MM 300L	1	

