

MODEL

DH 50MB

HITACHI
POWER TOOLS

HAMMER DRILL
DH 50MB

TECHNICAL DATA
AND
SERVICE MANUAL

D

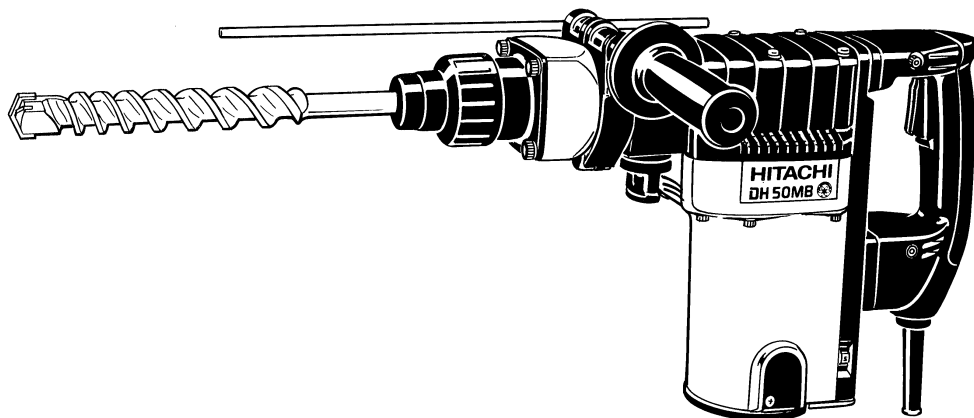

LIST No. E455

Feb. 2000

SPECIFICATIONS AND PARTS ARE SUBJECT TO CHANGE FOR IMPROVEMENT

Notice for use

Specifications and parts are subject to change for improvement.
Refer to Hitachi Power Tool Technical News for further information.

CONTENTS

[Business Section]	Page
1. PRODUCT NAME	1
2. MARKETING OBJECTIVE	1
3. APPLICATIONS	1
4. SELLING POINTS	2
4-1. Selling Point Descriptions	3
5. SPECIFICATIONS	5
5-1. Specifications	5
5-2. Optional Accessories	6
6. COMPARISONS WITH SIMILAR PRODUCTS	10
6-1. Specification Comparisons	10
6-2. Drilling Speed Comparisons	11
6-3. Chiseling Performance	12
7. PRECAUTIONS IN SALES PROMOTION	13
7-1. Handling Instructions	13
7-2. Caution Plate	13
8. REFERENCES	14
8-1. Grease Replacement Procedures	14
8-2. O-Ring Replacement	14
8-3. Structure of the DH 50MB Hammer Drill	15
[Service Section]	
9. PRECAUTIONS IN DISASSEMBLY AND REASSEMBLY	23
9-1. Disassembly	23
9-2. Reassembly	24
9-3. Screw Locking Agent TB1401	27
9-4. Tightening Torque	27
9-5. Wiring Diagrams	28
9-6. Insulation Test	28
9-7. No-Load Current Values	28
10. STANDARD REPAIR TIME (UNIT) SCHEDULES	29
[Appendix]	
Assembly Diagram for DH 50MB	30

1. PRODUCT NAME

Hitachi Hammer Drill, Model DH 50MB

2. MARKETING OBJECTIVE

The market demand for 50 mm (2") class hammer drills is quickly changing from spline or hexagon bit shank types to a SDS-MAX bit shank type, especially in the European market. The new Model DH 50MB, which features the SDS-MAX bit shank, has been developed to meet that market demand.

The main features of the Model DH 50MB are as follows:

- 1) High drilling speed and impact energy
- 2) Shock-absorbing handle
- 3) 2-mode function: Hammer drilling and hammering only
- 4) Compact and lightweight design
- 5) Soft-grip handle and side handle
- 6) Vario Lock mechanism (12 positions)
- 7) Constant speed with variable speed control
- 8) Warning display indicating service life of carbon brushes

3. APPLICATIONS

- Concrete drilling
- Drilling anchor bolt holes
- Crushing, chiseling, grooving, edging, cutting, stripping, compacting/tamping and roughing concrete surfaces

[Application examples]

- Air conditioning Installation of air conditioners and water coolers
- Piping and wiring Electric, gas and water supply work
- Electric fixtures Installation of electric and lighting fixtures
- Sanitary facilities Sanitary plumbing
- Interior finishing Installation of seats, display counters, ducts and interior decoration
- Other building, construction and repair work

4. SELLING POINTS

Compact and lightweight: Overall length 495 mm (19-1/2"), Weight 9.8 kg (21.6 lbs.)

B : Overall length 595 mm (23-1/2"), Weight 10.8 kg (23.8 lbs.)

C : Overall length 610 mm (24-1/32"), Weight 10.0 kg (22.0 lbs.)

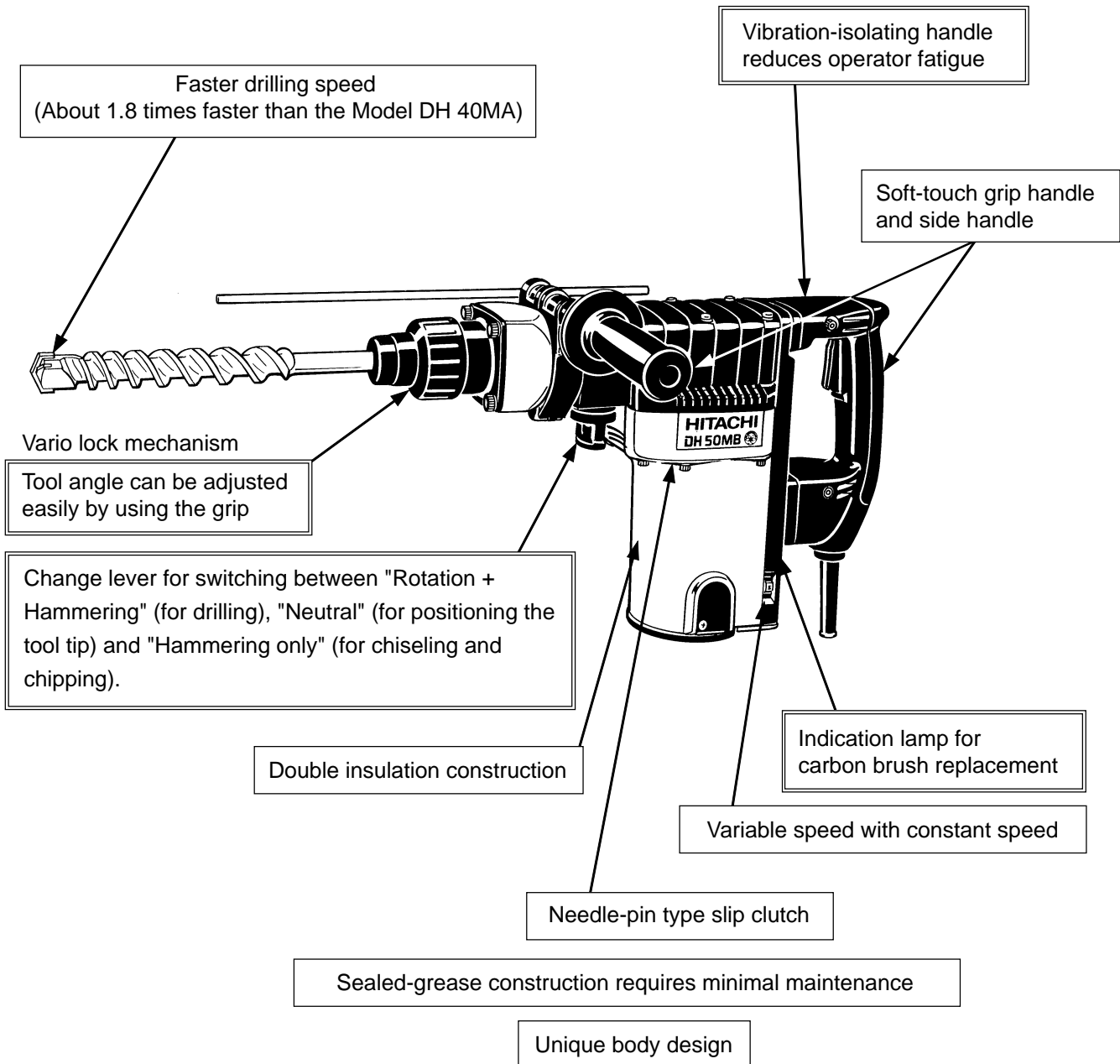

Fig. 1

4-1. Selling Point Descriptions

4-1-1. Dial type, constant speed electronic control with stepless variable-speed

The Model DH 50MB contains an electronic control circuit which allows the number of revolutions and the number of strikes to be stepless adjustable from levels 1 to 5 on the dial. The number of revolutions and the number of strikes are within the range of values in the graph shown below, due to variations of products.

The constant speed control minimizes the change in the number of revolutions or number of strikes at the position set on the dial even if the load fluctuates, thus providing ease of use and stable drilling efficiency.

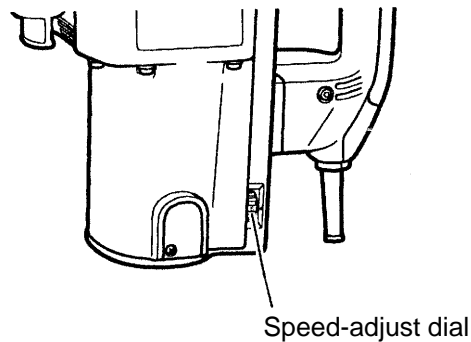

Fig. 2

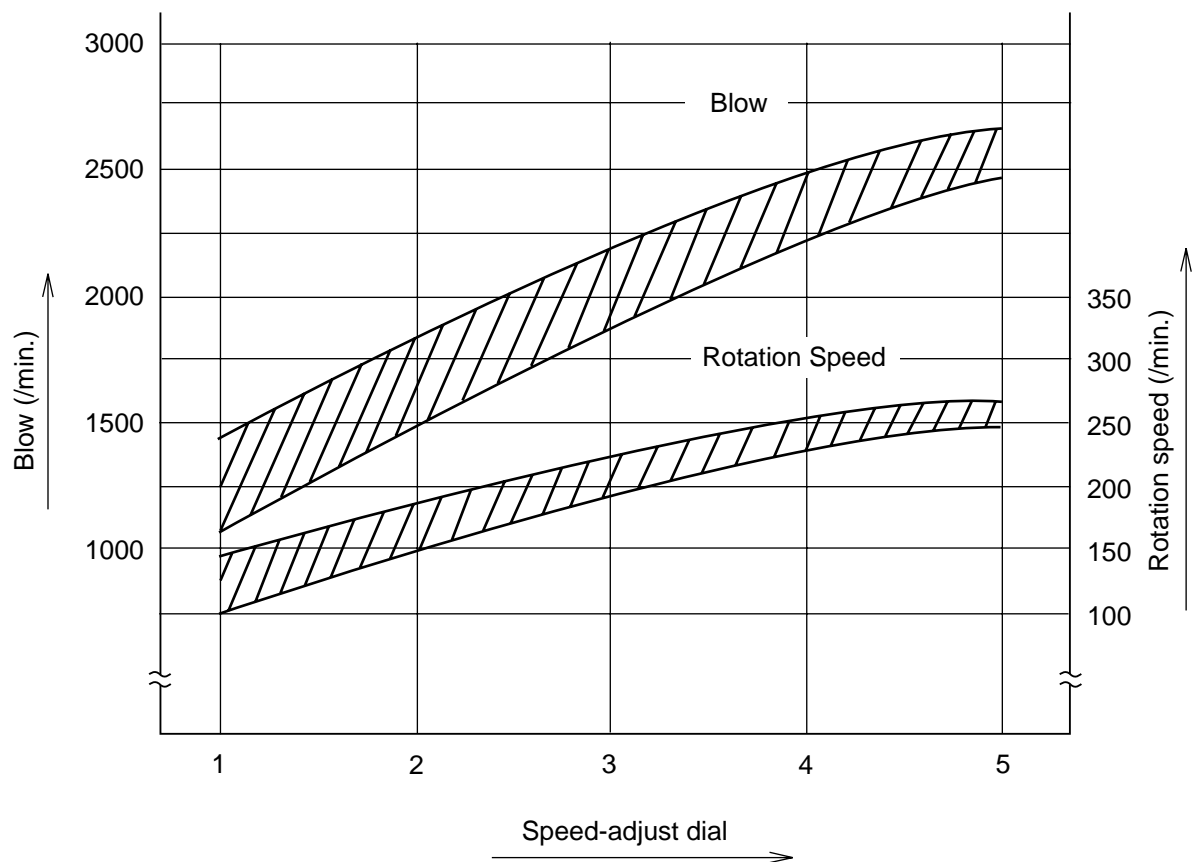

Fig. 3

4-1-2. Faster drilling speed

The drilling speed is 1.8 times faster than that of the Model DH 40MA, as the Model DH 50MB has greater striking energy owing to the optimized design of the rotation speed, striking frequency and the weight of striker.

4-1-3. Vibration-isolating handle offers less operator fatigue

The two vibration-isolating rubbers provided between the handle and the crank case, and also between the handle and the housing efficiently absorb the vibration transmitted from the tool main body to minimize transmission of vibration to the operator's arms.

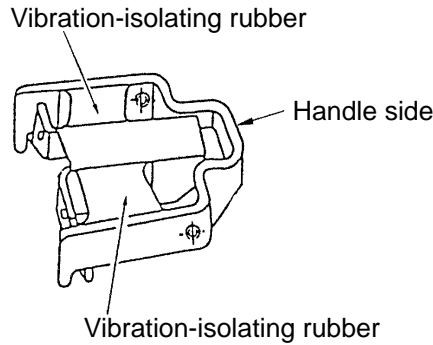

4-1-4. Indication lamp for carbon brush replacement

The indication lamp will light up (red) approximately 10 hours before the service life of the carbon brushes ends to notify the operator that the carbon brushes should be replaced with new ones. Replacement of carbon brushes at the proper time can prevent sudden stop of the motor and result in more efficient operation.

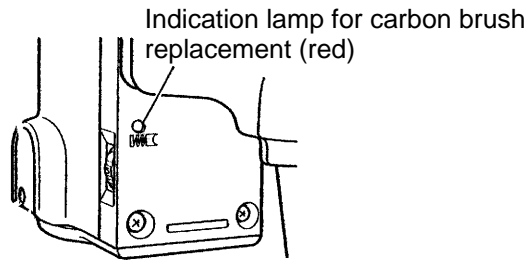

4-1-5. Easy-to-use tool holder

The easy-to-grip tool holder allows the tool to be attached and removed simply by sliding the grip backward.

4-1-6. Soft-touch grip handle and side handle

The double-layer molded handle and side handle consist of a plastic resin base covered with a soft plastic layer to ensure a soft touch and easy grip of the handles.

4-1-7. Change lever for switching between "rotation + hammering", "neutral" and "hammering only"

The Model DH 50MB provides three functions, "rotation + hammering" function (for drilling), "neutral" function (for positioning the tool tip) and "hammering only" function (for chiseling and chipping). These function modes can be easily switched using the change lever located under the cylinder case. This permits accurate centering and positioning because the function mode can be switched to the hammering only function mode with the drill bit (for concrete drilling) mounted.

4-1-8. Needle-pin type slip clutch

The Model DH 50MB is equipped with a needle-pin type slip clutch to ensure a greater accuracy of slip torque and enhanced safety.

5. SPECIFICATIONS

5-1. Specifications

Capacity		Drill bit (max. diameter); 50 mm (2"), Core bit (max. diameter); 160 mm (6-1/4")						
Power Source		AC single phase 50 Hz or 60 Hz						
Voltage, current and power input		Voltage (V)	110	115	127	220	230	240
		Current (A)	13.4	12.8	11.6	6.6	6.4	6.2
		Power input (W)	1400					
Rotation speed	No-load	120 – 250 /min.						
	Full-load	120 – 250 /min.						
Full-load blow		1200 – 2500 /min.						
Type of motor		AC single-phase commutator motor						
Type of switch		Trigger switch						
Type of handle		D-type handle and side handle						
Insulation structure		Double insulation						
Enclosure		Material: Housing Glassfiber reinforced polyamide resin (green) Handle Handle cover } Glassfiber reinforced polyamide resin (black and gray) Crank case cover }						
Dimensions		495 mm x 293 mm x 120 mm (length x height x width) (19-1/2" x 11-9/16" x 4-3/4")						
Plastic case color		Off-black green						
Weight	Net*	9.8 kg (21.6 lbs.)						
	Gross	15.2 kg (33.5 lbs.)						
Packaging		Corrugated cardboard box						
Standard accessories		Plastic case 1 Side handle 1 Hex. bar wrench 4 mm 1 Hex. bar wrench 5 mm 1 Hex. bar wrench 6 mm 1 Stopper 1 Grease (A) 1						

*: Net weight does not include cord and side handle.

5-2. Optional Accessories

1. Drilling work for through-holes (rotation + hammering)

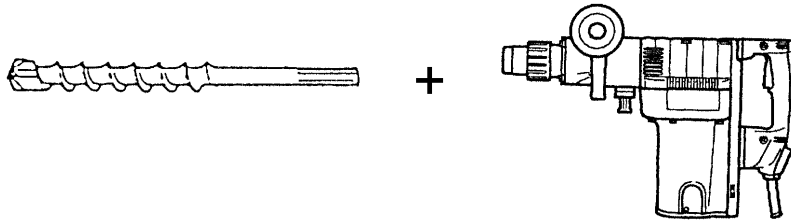

(1) Drill bit (SDS max shank)

Outer diameter (mm)	Overall length (mm)	Code No.
16 (5/8")	340 (13-3/8")	313448
19 (3/4")	340 (13-3/8")	313449
22 (7/8")	320 (12-5/8")	313450
25 (1")	320 (12-5/8")	313451
28 (1-1/8")	370 (14-9/16")	313452
32 (1-1/4")	370 (14-9/16")	313453
38 (1-1/2")	370 (14-9/16")	313454
40 (1-9/16")	370 (14-9/16")	313455

Outer diameter (mm)	Overall length (mm)	Code No.
16 (5/8")	540 (21-1/4")	313456
19 (3/4")	540 (21-1/4")	313457
22 (7/8")	520 (20-15/32")	313458
25 (1")	520 (20-15/32")	313459
28 (1-1/8")	570 (22-7/16")	313460
32 (1-1/4")	570 (22-7/16")	313461
38 (1-1/2")	570 (22-7/16")	313462
40 (1-9/16")	570 (22-7/16")	313463

2. Drilling work for anchor holes (rotation + hammering)

Drill bit (taper shank)



(1) Drill bit (taper shank)

(2) Taper shank adapter

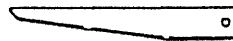
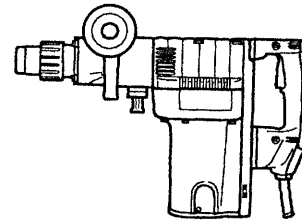

(3) Cotter

(1) Drill bit (taper shank)		(2) Taper shank adapter		(3) Cotter
Outer diameter(mm)	Code No.	Taper dimension	Code No.	Code No.
11 (7/16")	944460	Morse taper No. 1	313464	944477
12.3 (15/32")	944461			
12.7 (1/2")	993038			
14.3 (9/16")	944462			
14.5 (9/16")	944500			
17.5 (11/16")	944463			

SDS-plus shank bit adapter

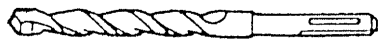

(1) Drill bit (SDS-plus shank)

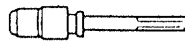

(2) SDS-plus shank bit adapter

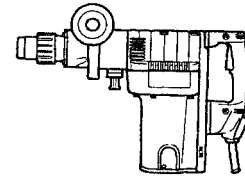

Code No. 313465

3. Boring work for large-diameter holes (rotation + hammering)



(1) Guide plate

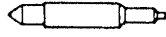

(2) Center pin

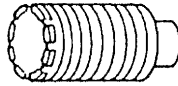

(3) Core bit

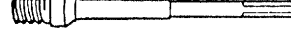

(4) Core bit shank

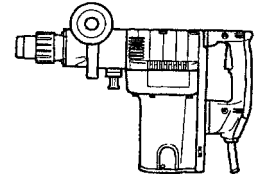

(1) Guide plate

Core bits with outer diameter of 32, 35, 38, 45, 50, 54, 60, 64, 70, 75, 79, 94, 100, 105, 120, 150 mm (1-1/4", 1-3/8", 1-1/2", 1-3/4", 2", 2-1/8", 2-3/8", 2-1/2", 2-3/4", 2-15/16", 3-1/8", 3-11/16", 3-15/16", 4-1/8", 4-3/4", 6")

[Guide plate is not used with core bits with outer diameter of 25 mm (1") and 29 mm (1-1/8")]

(2) Center pin

- Code No. 956009 for core bits with outer diameter of 32, 35 mm (1-1/4", 1-3/8")
- Code No. 955165 for core bits with outer diameter of 38, 45, 50, 54, 60, 64, 70, 75, 79, 94, 100, 105, 120, 150 mm (1-1/2", 1-3/4", 2", 2-1/8", 2-3/8", 2-1/2", 2-3/4", 2-15/16", 3-1/8", 3-11/16", 3-15/16", 4-1/8", 4-3/4", 6")

[Center pin is not used with core bits of 25 mm (1") and 29 mm (1-1/8")]

(3) Core bit

Outer diameter (mm)	Code No.	Outer diameter (mm)	Code No.
25 (1")	955994	75 (2-15/16")	959709
29 (1-1/8")	955995	79 (3-1/8")	955157
32 (1-1/4")	955996	94 (3-11/16")	956004
35 (1-3/8")	955998	100 (3-15/16")	959710
38 (1-1/2")	956000	105 (4-1/8")	955159
45 (1-3/4")	955154	120 (4-3/4")	956006
50 (2")	959706	150 (6")	956728
54 (2-1/8")	955155		
60 (2-3/8")	959707		
64 (2-1/2")	956002		
70 (2-3/4")	959708		

(4) Core bit shank

- Code No. 313466 for core bits with outer diameter of 25, 29, 32, and 35 mm (1", 1-1/8", 1-1/4", and 1-3/8")
- Code No. 313467 for core bits with outer diameter of 38, 45, 50, 54, 60, 64, 70, 75, 79, 94, 100, 105, 120, 150 mm (1-1/2", 1-3/4", 2", 2-1/8", 2-3/8", 2-1/2", 2-3/4", 2-15/16", 3-1/8", 3-11/16", 3-15/16", 4-1/8", 4-3/4", 6")

4. Hole drilling For drilling steel and wood

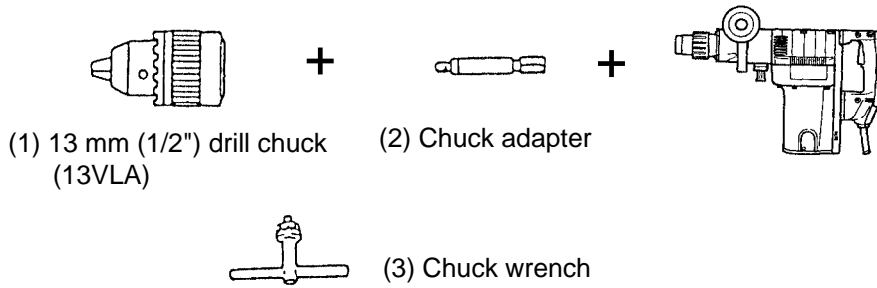

(1) 13 mm (1/2") drill chuck (13VLA)	(2) Chuck adapter	(3) Chuck wrench
Code No. 950272	Code No. 313468	Code No. 930515

5. Chemical anchor hole drilling work (rotation + hammering)

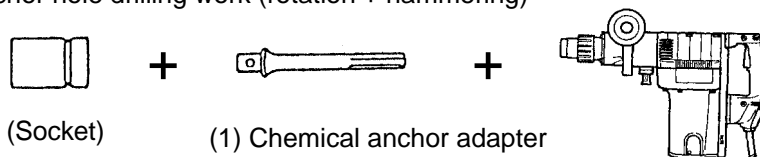

Socket square size	Code No.
12.7 mm (1/2")	313469
19.0 mm (3/4")	313470

6. Demolition work (hammering)

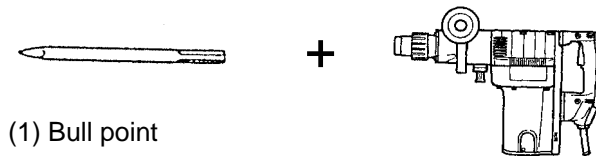

Overall length	Code No.
280 mm (11")	313471
400 mm (15-3/4")	313472

7. Grooving and edging (hammering)

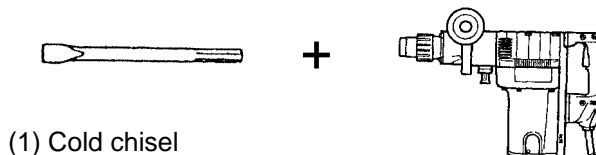

Overall length	Code No.
280 mm (11")	313473
400 mm (15-3/4")	313474

8. Cutting and stripping (asphalt cutting, etc.) (hammering)

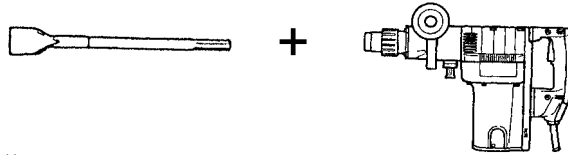

(1) Cutter

Width	Overall length	Code No.
50 mm (2")	400 mm (15-3/4")	313475

9. Digging (substitute pick-ax) (hammering)

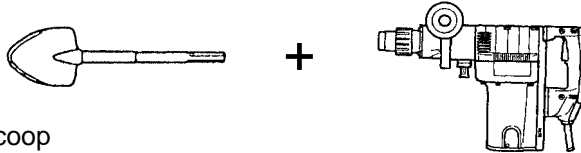

(1) Scoop

Overall length	Code No.
400 mm (15-3/4")	313476

10. Surface roughing work (hammering)

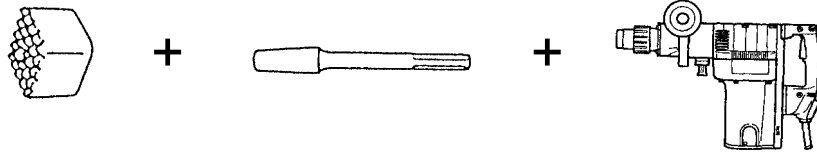

(1) Bushing tool

Code No. 313477

(2) Shank

Overall length	Code No.
220 mm (8-21/32")	313479

11. Tamping work (hammering)

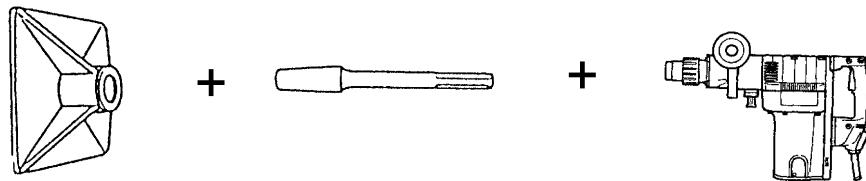

(1) Rammer

Code No. 313478
150 mm x 150 mm

(2) Shank

Overall length	Code No.
220 mm (8-21/32")	313479

12. Syringe (for chip removal)

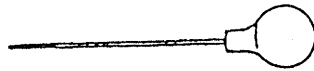

Code No. 944575

13. Impact drill grease

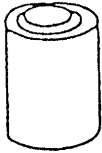

500 g can

Code No. 980927

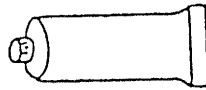

70 g tube

Code No. 308471

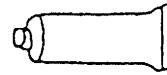

30 g tube

Code No. 981840

Note: Code numbers listed above are subject to change without notice.

Please refer to periodic Technical News Bulletins for updates.

6. COMPARISONS WITH SIMILAR PRODUCTS

6-1. Specification Comparisons

Item		Maker, Model	HITACHI DH 50MB	B	D
Capacity	Drill bit dia. (mm)		50 (2")	52 (2")	37 (1-7/16")
	Core bit dia. (mm)		160 (6-1/4")	150 (6")	160 (6-1/4")
Power input (W)			1400	1500	1050
Power output (W)					
Rotation speed	No-load (/min.)		120 – 250	120 – 250	0 – 255
	Full-load (/min.)		120 – 250	120 – 250	0 – 255
Full-load blow (/min.)			1200 – 2500	1100 – 2250	0 – 2700
Weight (kg)*	Catalog weight		9.8 (21.6 lbs.)	10.8 (23.8 lbs.)	7.9 (17.4 lbs.)
	Actual weight		10.3 (21.6 lbs.)	10.8 (23.8 lbs.)	N/A
Dimensions	Overall length (mm)		495 (19-1/2")	595 (23 -1/2")	495 (19-1/2")
	Height (mm)		293 (11-9/16")	280 (11-1/32")	259 (10-7/32")
	Width (mm)		120 (4-3/4")	128 (5-1/16")	115 (4-17/32")
Insulation structure			Double insulation	Double insulation	Double insulation
Full-load vibration level (dB)			120	120	119
No-load sound pressure level (dB/A)			87	85	84

*Weight does not include cord and side handle.

6-2. Drilling Speed Comparisons

Drilling speed varies considerably depending on the work conditions. Use the factory test results shown in Fig. 4 as a reference, for comparison purposes only.

Fig. 4

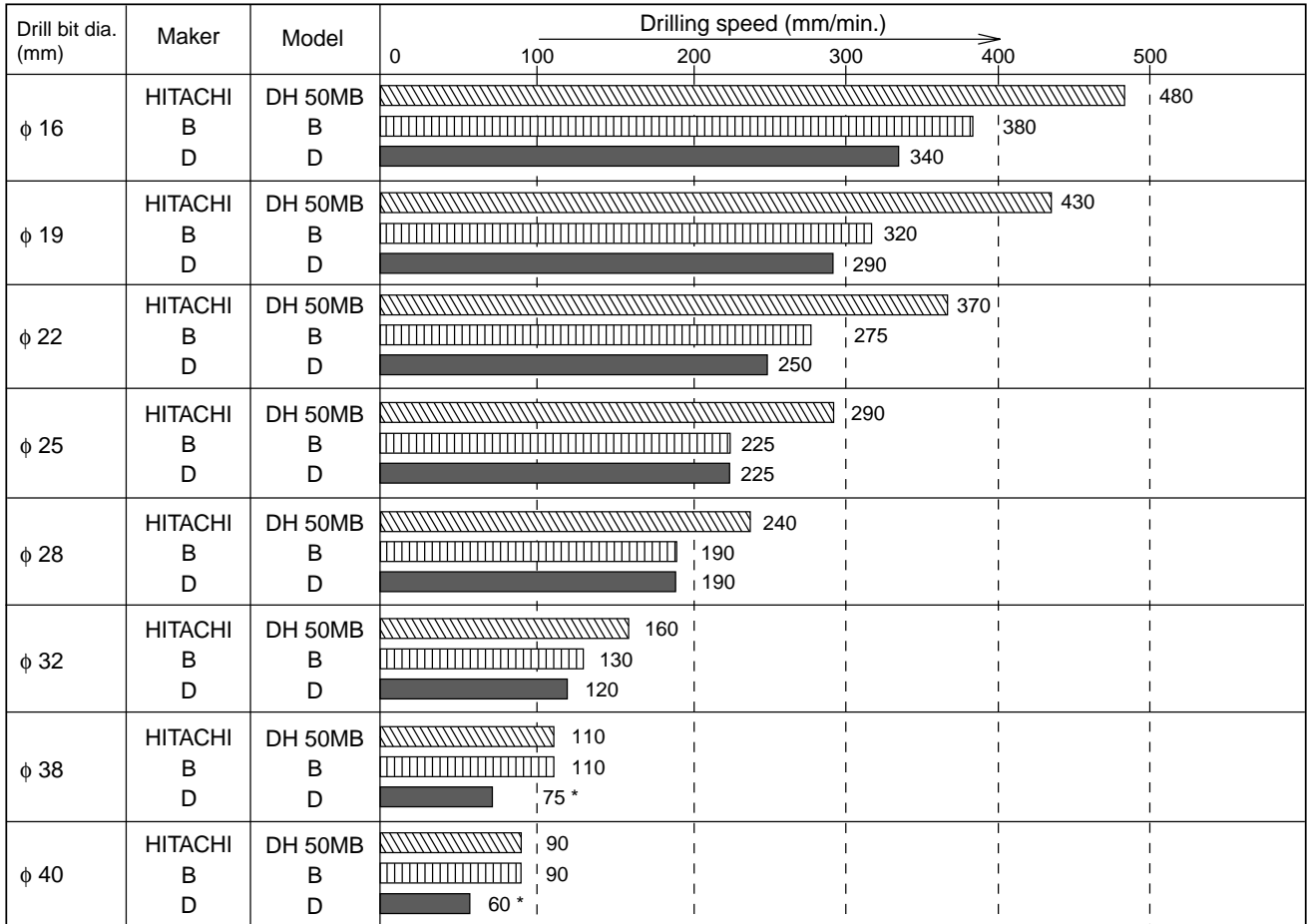

*: Note that the data marked with asterisks are test results using drill bits which are beyond the tool's rated capacity. Use the above data as a reference, for comparison purposes only.

[Test conditions]

Orientation : Downward drilling

Pressing force : 10 kgf

Test material : Concrete panel with a compression strength of 240 kgf/cm²

Drill bit size : SDS-max shank drill bit

6-3. Chiseling Performance

Chiseling performance varies considerably depending on the work conditions. Use these factory test results shown in Fig. 5 for comparison purposes only.

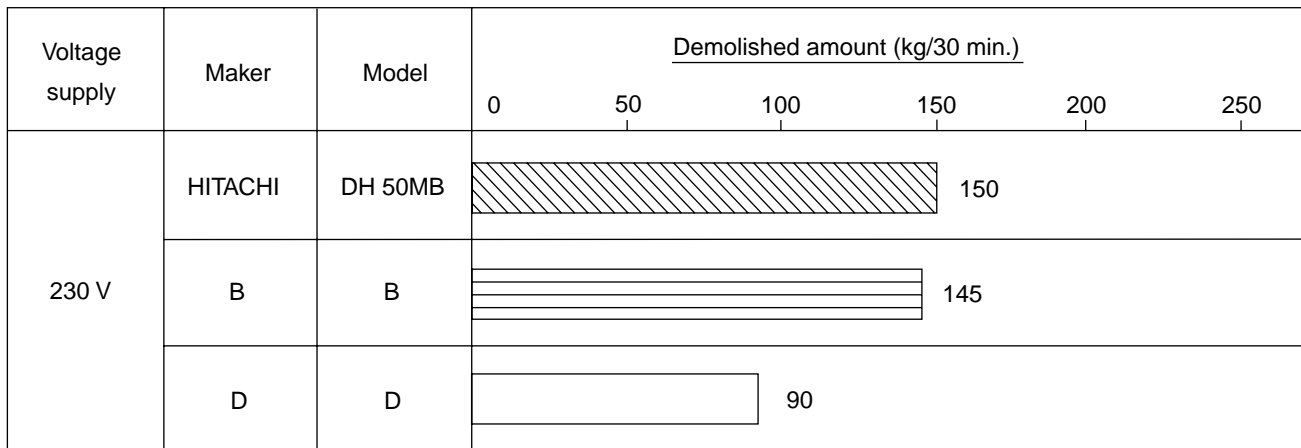

Fig.5

[Test conditions]

Orientation : Downward chiseling

Test material : Concrete panel with a compression strength of 2,919 N/cm² (240 kgf/cm²)

Bull point : SDS-max shank bull point of 280 mm

7. PRECAUTIONS IN SALES PROMOTION

In the interest of promoting the safest and most efficient use of the Model DH 50MB Hammer Drill by all of our customers, it is very important that at the time of sales the salesperson carefully ensures that the buyer seriously recognizes the importance of the contents of the Handling Instructions, and fully understands the meaning of the precautions listed on the Caution Plate attached to each tool.

7-1. Handling Instructions

Although every effort is made in each step of design, manufacture and inspection to provide protection against safety hazards, the dangers inherent in the use of any electric power tool cannot be completely eliminated. Accordingly, general precautions and suggestions for the use of electric power tools, and specific precautions and suggestions for the use of the Hammer Drill are listed in the Handling Instructions to enhance the safe, efficient use of the tool by the customer. Salespersons must be thoroughly familiar with the contents of the Handling Instructions to be able to offer appropriate guidance to the customer during sales promotion.

7-2. Caution Plate

Each Model DH 50MB unit is provided with a Caution Plate (illustrated below) which lists basic safety precautions for its use. Carefully ensure that the customer fully understands and follows these precautions before using the tool.

- (1) For Australia, New Zealand and China

CAUTION

- Read thoroughly **HANDLING INSTRUCTIONS** before use.

- (2) For the U.S.A. and Canada

WARNING

- To reduce the risk of injury, user must read and understand instruction manual.

AVERTISSEMENT

- Afin de réduire le risque de blessures, l'utilisateur doit lire et bien comprendre le mode d'emploi.

- (3) For Taiwan

使用前請詳讀使用說明書

8. REFERENCES

8-1. Grease Replacement Procedures

The electro-pneumatic hammering section and gear change section each use different kinds of grease.

It is not necessary to replenish the grease unless the tool is disassembled for repair or there is a grease leakage due to a damaged seal.

A special grease is used for the hammering section. To change the grease in the hammering section (Cylinder Case and Crank Case), carefully wipe the old grease off the parts, and re-lube with 30 g in the Cylinder Case and 75 g in the Crank Case (on the Connecting Rod side). Take care not to overfill with grease as an excessive amount of grease can cause hammering failure.

The gear change section (in the Gear Cover) uses grease No. 29 for power tools. Lube with 40 g of this grease. Do not use the special grease used for the hammering section, or it will leak to the motor parts resulting in failure of the tool.

8-2. O-Ring Replacement

The O-ring (attached to the Striker and Piston) plays an important role to ensure air tightness. Despite its prolonged service life due to its special rubber material, it will inevitably wear out. Early replacement, preferably once every six months, is recommended.

8-3. Structure of the DH 50MB Hammer Drill

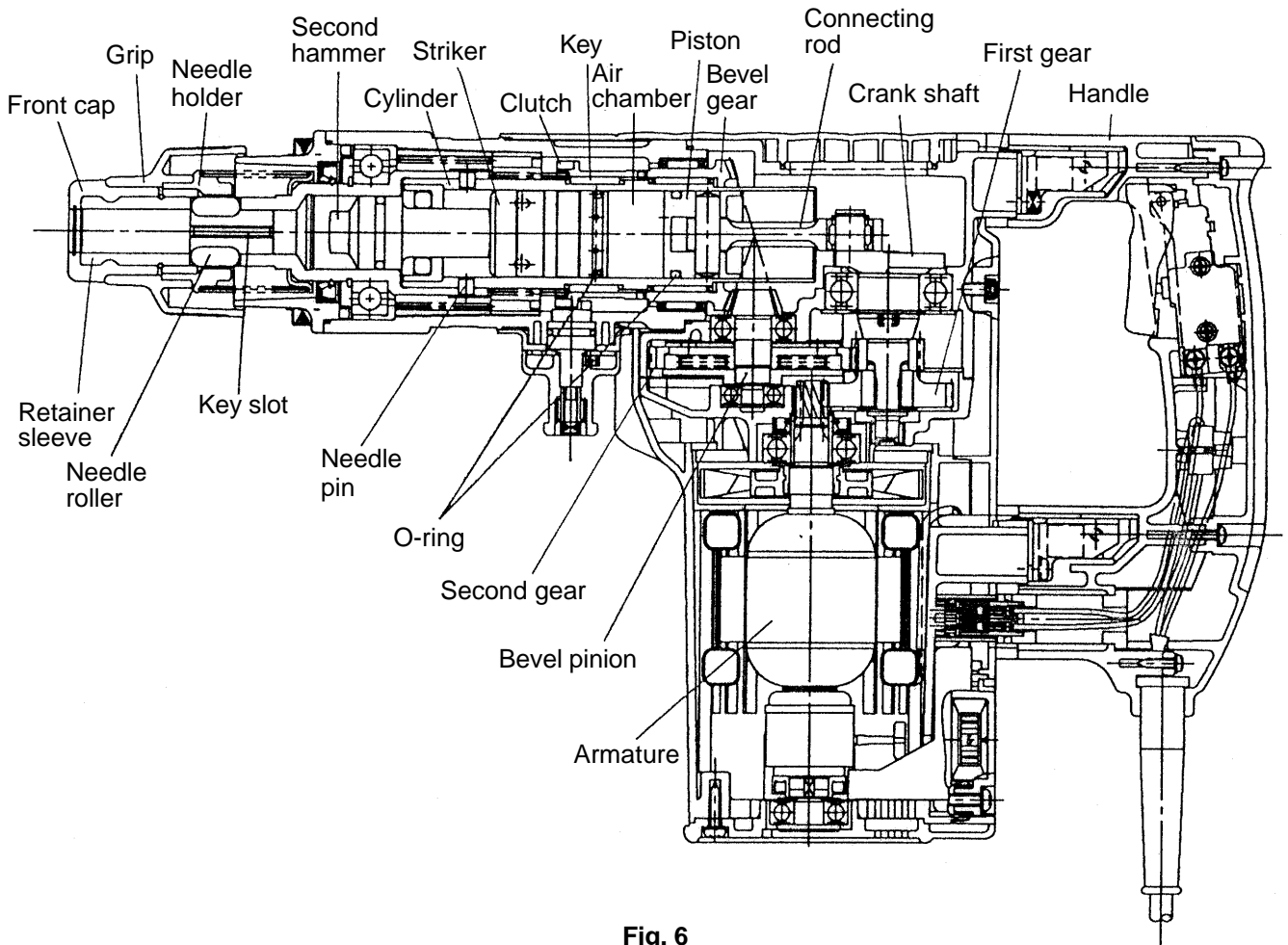

Fig. 6

- Torque transmission

Rotation transmission is described below with reference to Fig. 6. The gear arrangement of the Model DH 50MB has the armature shaft positioned between the crank shaft and bevel pinion shaft. Rotation of the armature shaft is transmitted to the second gear through the first gear of the crank shaft and the second pinion. Then the rotation is transmitted from the second gear through the slip mechanism disposed between the second gear and the bevel pinion shaft to turn the bevel gear. The bevel gear is keyed to the cylinder through the clutch to rotate together. Rotation of the cylinder is transmitted to the retainer sleeve coupled together by means of four needle pins, and then to the drill bit inserted into the retainer sleeve by way of three key slots and two needle rollers which couple them together.

- Hammering

Armature rotation is transmitted to the crank and connecting rod so that the piston moves reciprocally within the cylinder. Air pressure developing between the piston and the striker changes with movement of the piston. The internal pressure thus pushes the striker to repeatedly strike the end face of the second hammer. Since the striker is moved by means of air pressure, the cushioning effect of the air absorbs the hammering shock experienced by the operator. If air leaks from the air pressure chamber, the cushioning effect will not be enough to absorb shock. O-rings fitted around the striker and piston for air sealing therefore play an important role for the intended function of this hammer drill.

- Switching between "Drill + Hammering", "Neutral" and "Hammering only"

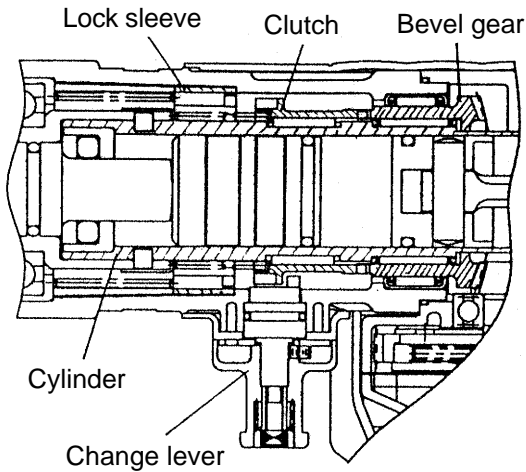

Fig. 7

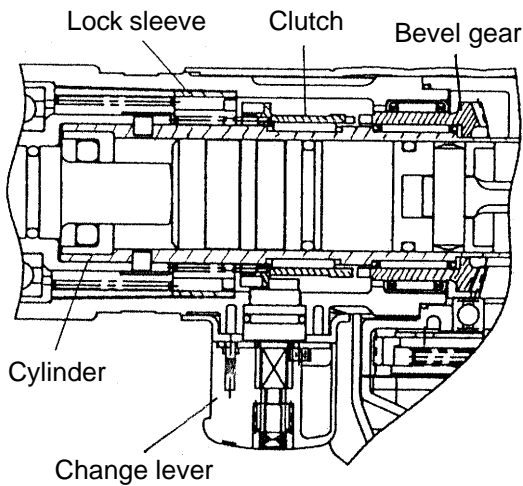

Fig. 8

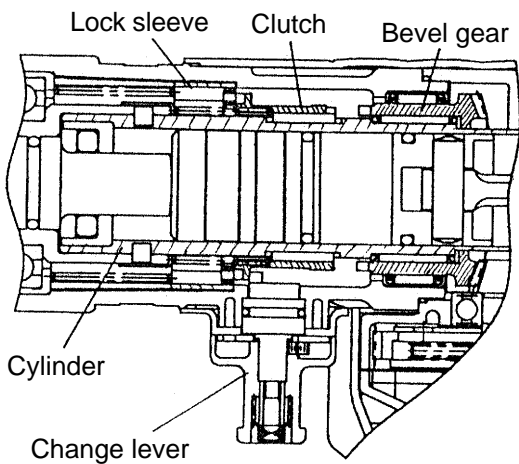

Fig. 9

The shanks of the SDS max type working tools are all of the same shape for drill bits, bull points for chiseling and chipping and cold chisels. When chiseling and chipping with this hammer drill, it is necessary to stop the drilling motion and choose the "Hammering only" mode by means of the change lever to lock the working tool against rotation.

The change lever mechanism is described below with reference to Figs. 7, 8 and 9.

Fig. 7 is a cross-sectional view showing the "Rotation + Hammering" mode, in which the bevel gear dog meshes with the clutch dog to transmit rotation to the cylinder keyed to the clutch, so as to rotate the working tool.

Fig. 8 is a sectional view showing the "Neutral" mode, in which, with the change lever turned 90°, the bevel gear is brought out of engagement with the clutch to cut off power transmission. In this position, the tool holder grip can be manually turned to enable easier positioning of the working tool for chiseling and chipping.

Fig. 9 is likewise a sectional view showing the "Hammering only" mode. With the change lever turned another 90°, the clutch comes into mesh with the lock sleeve, and the splines on the outer circumference of the lock sleeve come into mesh with the splines on the internal face of the cylinder case, so that the cylinder as well as the working tool are prevented from rotating.

Since this hammer drill has three switchable modes as mentioned above, serious accidents may result if a tool for chipping or chiseling should be used in the "Rotation + Hammering" mode. Ensure that your customers are advised to always use the "Hammering" mode when doing chiseling or chipping work.

- Mechanism to prevent idle hammering

The arrangement against idle hammering of this hammer drill is about the same as for the DH 40MA/MB in which, when the drill bit or bull point is no longer pressed against the concrete or similar material, the second hammer moves to a position shown in Fig. 10 so that the striker is displaced from its hammering position. This opens the air vent so that the piston movement causes no change in air pressure in the pressure chamber, thus stopping the hammering action.

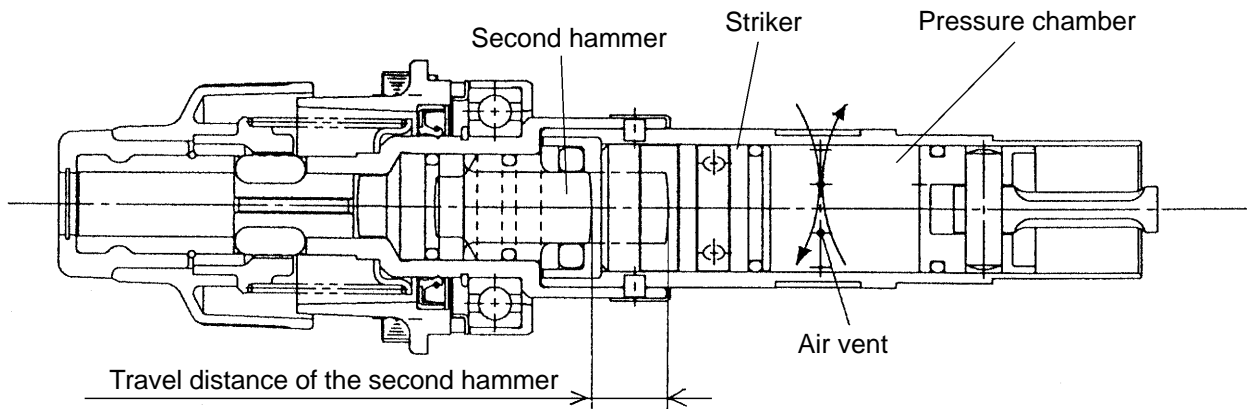

Fig. 10

- Slip mechanism

The slip mechanism is described below with reference to Fig. 11. The bevel pinion and the gear holder are coupled together by the key and press-fitting. The springs (C) and the needle pins are housed in elongated grooves of the gear holder. The needle pin is pressed against the inner face of the second gear by the springs (C) to allow idle rotation of the second gear relative to the gear holder. When an excess torque is exerted on the bevel pinion shaft, the needle pin is raised upon the projection of the second gear against the load of the springs (C) to allow idle rotation of the second gear. With this arrangement, the clutch slips when an excessive torque is applied to the working tool as when the drill bit contacts steel bar/wire in the concrete, protecting the operator from unexpected motion of the side handle.

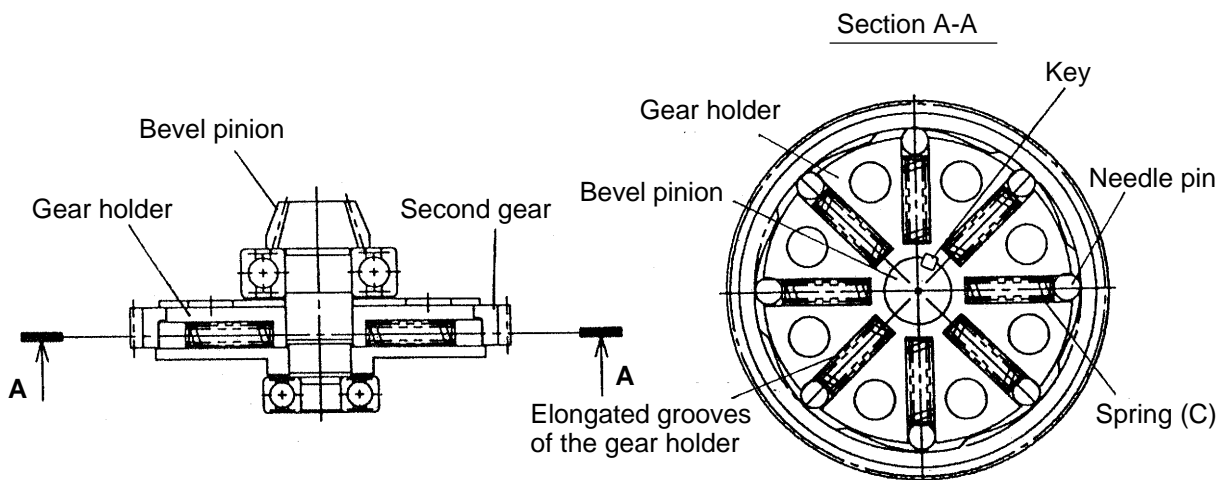

Fig. 11

- Drill bit

As illustrated in Fig. 12, the tool holder is designed to accept SDS max shank bits so that torque transmission to the drill bit is accomplished with three key rails formed on the tool holder, with two needle rollers provided to prevent the drill bit from slipping out.

The round shank, with an outer diameter of 18 mm, tends to attract less dust to itself or to the hammer drill itself. Also, the runout of drill bit becomes less by making the guide length of the shank longer.

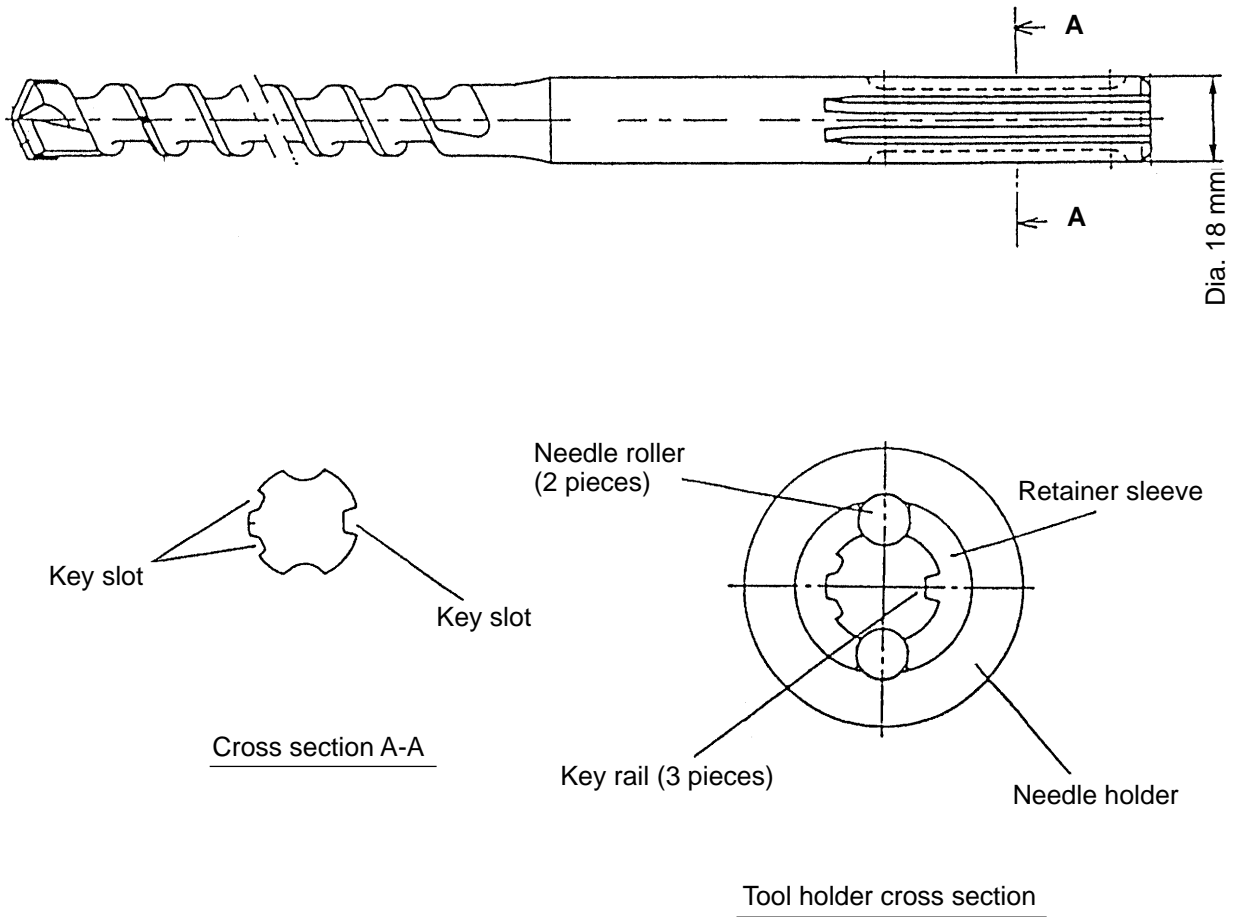

Fig. 12

- Tool holder

The tool holder is described below with reference to Fig. 13. The drill bit inlet is covered with a front cap (rubber) to prevent entry of cutting chips. Two needle rollers fit into the round groove of the drill bit to prevent it from slipping out of the tool holder, while the three key rails provide positive torque transmission to the drill bit. The drill bit can be easily removed simply by pulling back the grip. The grip is spring-loaded in the forward direction so that pulling the grip fully backward allows the needle rollers to move away from the bit. When, on the other hand, the drill bit is pushed fully until it stops, rotating it by hand, the latter spring back to bring the drill bit to a locked position.

When removing the drill bit, pull the grip fully backward and pull the drill bit out.

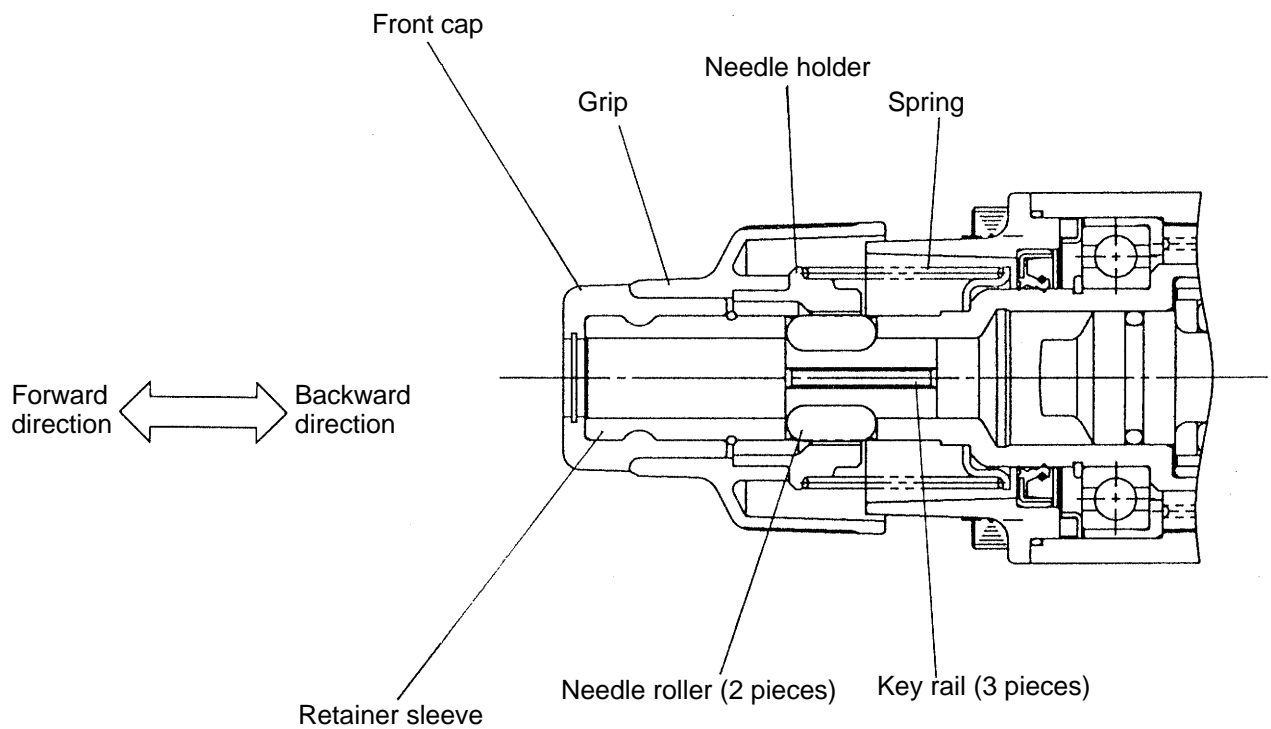

Fig. 13

- Wiring connections

The wiring connections are described below with reference to Fig. 14. The Model DH 50MB uses a plug-in module type wiring system consisting of plug (A) ass'y and plug (B) ass'y. The internal wires (2 and 3) of the control circuit ass'y and the internal wires from the stator, and the internal wire (5) of the control circuit ass'y and the internal wire from the piece ass'y, are press-connected by crimp-on connectors. The rest of the internal wires (1 and 4) of the control circuit ass'y are connected to the plug (A) ass'y, then the plug (A) ass'y is fitted into the housing. The plug (B) ass'y is fitted into the handle section through the plug holder and is connected with the switch terminal and cord. Wiring connection is complete when the housing section, the handle and handle cover section are all assembled and then fastened together with screws. With such a wiring structure, assembling and disassembling procedures associated with wiring connection have been largely simplified over previous models.

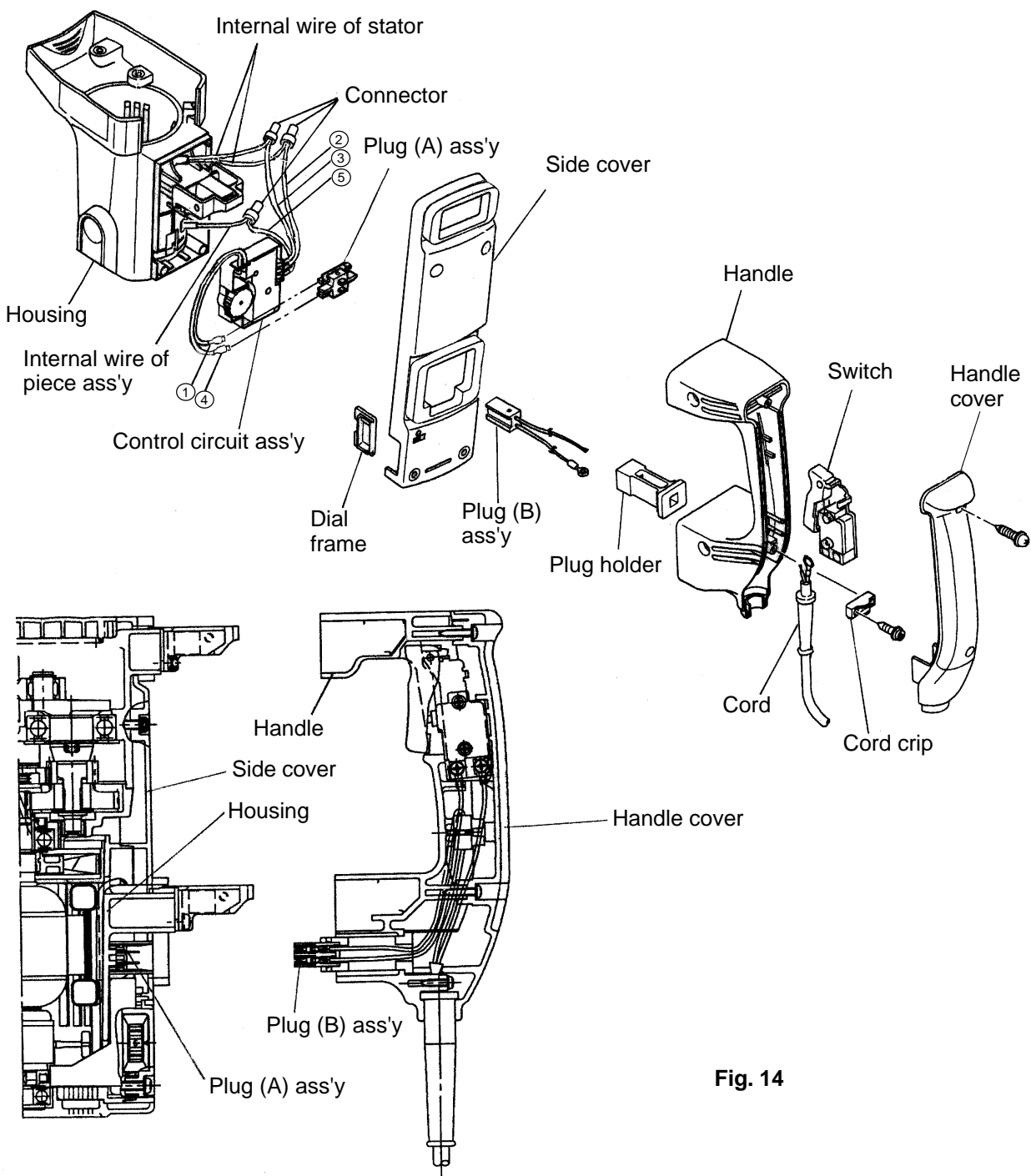

Fig. 14

- Handle and side handle

The handle section is of a two-layer structure consisting of a molded plastic base reinforced with glassfiber and a soft plastic layer molded together on the base.

The side handle is also constructed of two layers consisting of a reinforced plastic base molded together with steel nut and soft plastic surrounding the base.

This newly designed handle and side-handle structure ensure a lower vibration and a better, more comfortable grip for a improved operability.

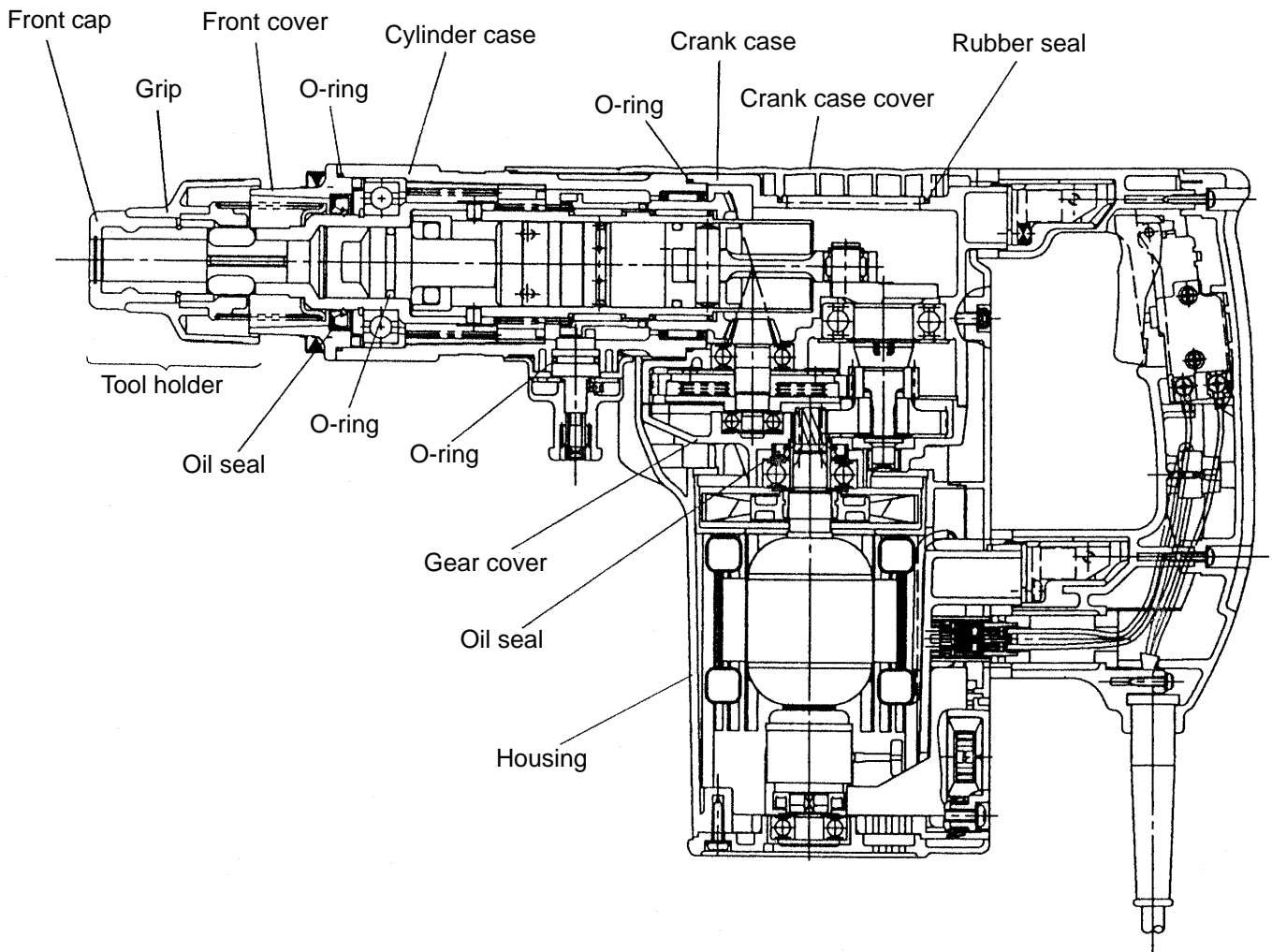

Fig. 15

- Sealing and dust-proof structure

The crank case and cylinder case section are tightly sealed with four O-rings, two oil seals and rubber seals as shown in Fig. 15. This prevents leakage of grease from the cases, while also protecting them against dust from the outside.

The tool holder is also protected from foreign dust by means of a rubber front cap.

- Indication lamp for carbon brush replacement

The indication lamp for carbon brush replacement is described below with reference to Fig. 16. As the carbon brush wears, the guide piece mounted to the carbon brush moves toward the commutator. When the guide piece contacts the piece ass'y, the indication lamp will light up in red as the switch is turned on. The indication lamp will begin to light up approximately 10 hours before the service life of the carbon brushes ends. When the indication lamp lights up, replace both carbon brushes with new ones as soon as possible.

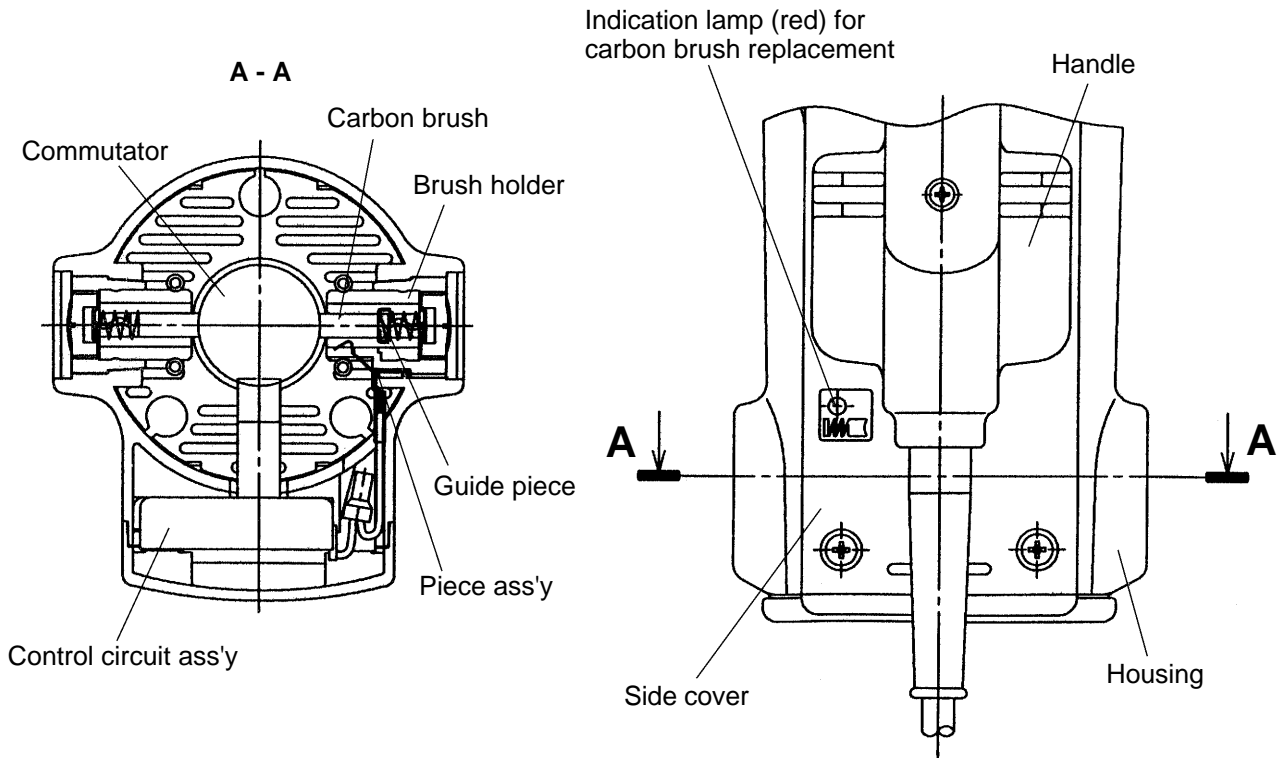

Fig. 16

9. PRECAUTIONS IN DISASSEMBLY AND REASSEMBLY

The **[Bold]** numbers in the descriptions below correspond to the item numbers in the Parts List and exploded assembly diagram.

9-1. Disassembly

(1) Piston and striker

Remove the four Nylock Bolts (W/Flange) M5 x 16 **[31]** at the Crank Case Cover Ass'y **[33]** and remove the latter. Remove the four Nylock Bolts (W/Flange) M6 x 35 **[59]** at the Cylinder Case **[58]** and pull the Cylinder Case out of the Crank Case **[35]**. Pull out the Piston Pin **[78]** and remove the Piston **[75]**. Remove the Connecting Rod Ass'y **[76]** from the Crank Shaft **[40]** by removing the Retaining Ring for D12 Shaft **[39]**. Pull out the Striker **[72]** by hammering on the Cylinder Case with a plastic hammer. If it is difficult to pull out the Striker, push the removed Piston together with the Connecting Rod Ass'y into the Cylinder **[67]** and quickly pull them out, and the Striker will jump out together with the Piston.

(2) Removing gears from the crank case

Remove the Retaining Ring for D17 Shaft **[47]** and the Thrust Washer **[46]** from the Crank Shaft **[40]**. Pull out the First Gear **[45]** with a bearing puller. Remove the Feather Key 5 x 5 x 15 **[29]**. Remove the Slip Clutch Ass'y **[27]** by hammering the Crank Case **[35]** from the Gear Cover **[50]** side with a plastic hammer. Remove the two Nylock Hex. Socket Hd. Bolts M5 x 16 **[38]** from the Bearing Cover **[43]** and pull out the Crank Shaft from the Gear Cover side.

The Slip Clutch Ass'y can be removed with the following procedure. First, pull out the Ball Bearing 629VV **[26]** with a bearing puller. Support Washer (A) **[20]** on a sleeve as shown in Fig. 17 and release the press-fitted Bevel Pinion **[16]** by pushing it from the Spacer **[25]** side using a hand press. When removing the Gear Holder **[21]** from the Second Gear **[24]**, it is recommended to keep them inside a vinyl bag during disassembly to prevent Springs (C) **[22]** and Needle Pins D6 x 6 **[23]** from scattering.

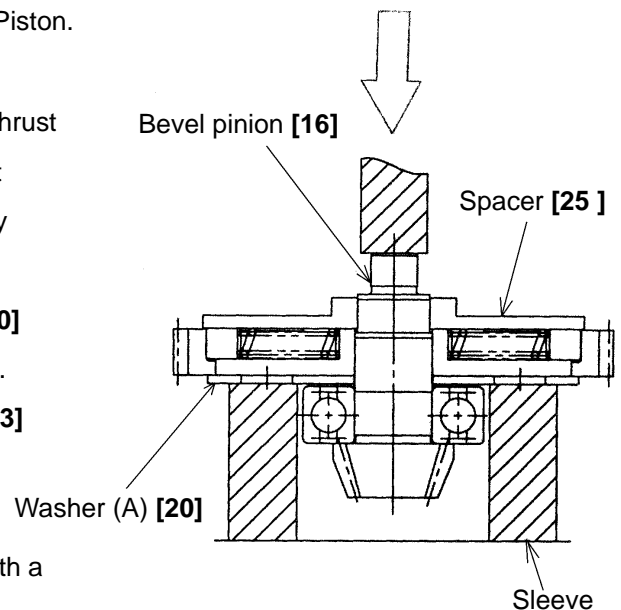

Fig. 17

(3) Disassembly of the tool holder

Slide the Grip **[2]** fully in direction indicated by the arrow as shown in Fig. 18 and remove the Front Cap **[1]** (since the Front Cap is made of rubber, grasp its outer face and strongly pull it to remove).

This allows the Grip, Stopper Ring **[3]**, Needle Holder **[4]**, Retainer Spring **[5]**, Needle Rollers (2 pcs.) **[51]** and Spring Holder **[6]** to be separated from the Retainer Sleeve **[52]**.

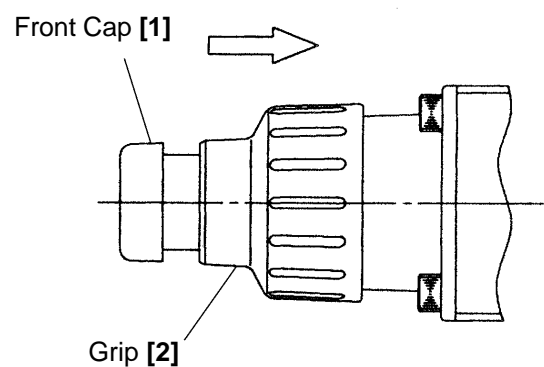

Fig. 18

9-2. Reassembly

Perform reassembly in the reverse order of disassembly while observing the given precautions and taking care of the following points.

(1) Lubrication

Apply special grease (for hammer and hammer drill) to the following portions.

- Inner circumference of the Connecting Rod Ass'y [76]
- Two O-Rings [73] attached to the Striker [72] and Piston [75]
- Inner lip portion of the Oil Seals [10] and [92]

Fill 30 g of special grease in the Cylinder Case [58] and 75 g of special grease in the Crank Case [35] of the connecting rod side. Apply power tool grease No. 29 to the Needle Bearing [49] and armature pinion. Fill 40 g of power tool grease No. 29 in the gear section of the gear cover and the crank case, and 20 g between the slip clutch (washer (A) side) and the crank case.

(2) Oil seal and others

Handle with care not to damage the Rubber Seal [34] in the Crank Case [35], two O-Rings [73] in the Piston [75] and Striker [72], O-Ring [53] in the Second Hammer [54], O-Ring (D) [62] in the Cylinder Case [58], O-Ring [9] in the Front Cover [8], O-Ring [83] in the Lever Shaft [84], Oil Seal [10] in the Front Cover [8] and Oil Seal [92] in the Gear Cover [50].

(3) Slip clutch ass'y

Press-fit the Ball Bearing 6202 [18] into the Bevel Pinion [16] and insert the Washer [19] and then Washer (A) [20] into the Bevel Pinion. After mounting the Feather Key 3 x 3 x 8 [17] in the Bevel Pinion, press-fit the Gear Holder [21] into the Bevel Pinion. Next, apply special grease (for hammer and hammer drill) to the inner circumference of the Second Gear [24]. Install the Second Gear [24] on the outer circumference of the Gear Holder and place the Needle Pins [23] without inclination as indicated in Fig. 19, then press the Springs (C) [22]. Press in the Spacer [25] and then Ball Bearing 629 [26].

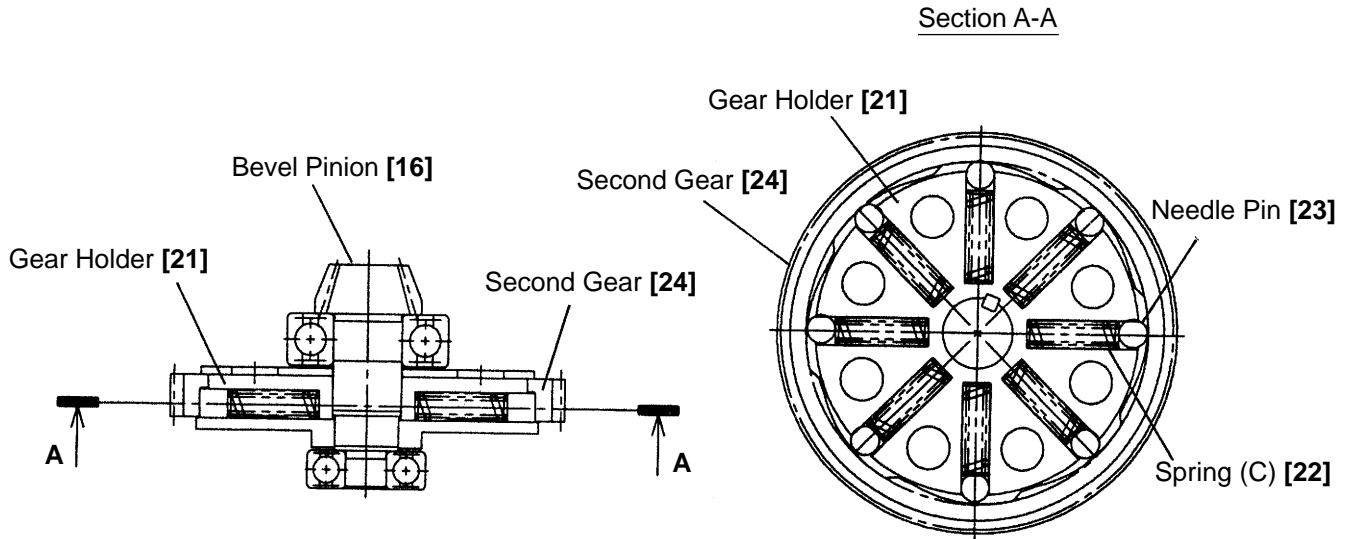

Fig. 19

(4) Inspecting the carbon brushes

The motor employs auto-stop carbon brushes. When the carbon brushes near their wear limit, the motor stops automatically. At that time, replace both carbon brushes with new ones which have the same carbon brush number "77" as shown in Fig. 20. In addition, always keep carbon brushes clean and ensure that they slide freely within the brush holders.

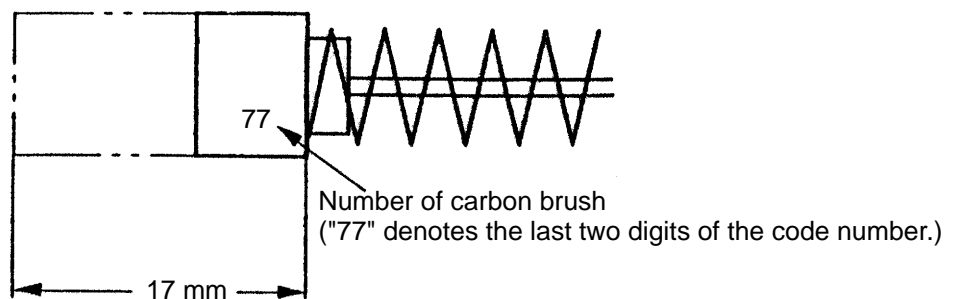

Fig. 20

(Caution)

The factory-installed carbon brushes are not identical to each other as shown in Fig. 21. Pay attention to their difference when reassembling after inspection. There is no problem when replacing them with a pair of carbon brushes supplied as service parts (No. 77) because both parts are the same type (guide piece provided).

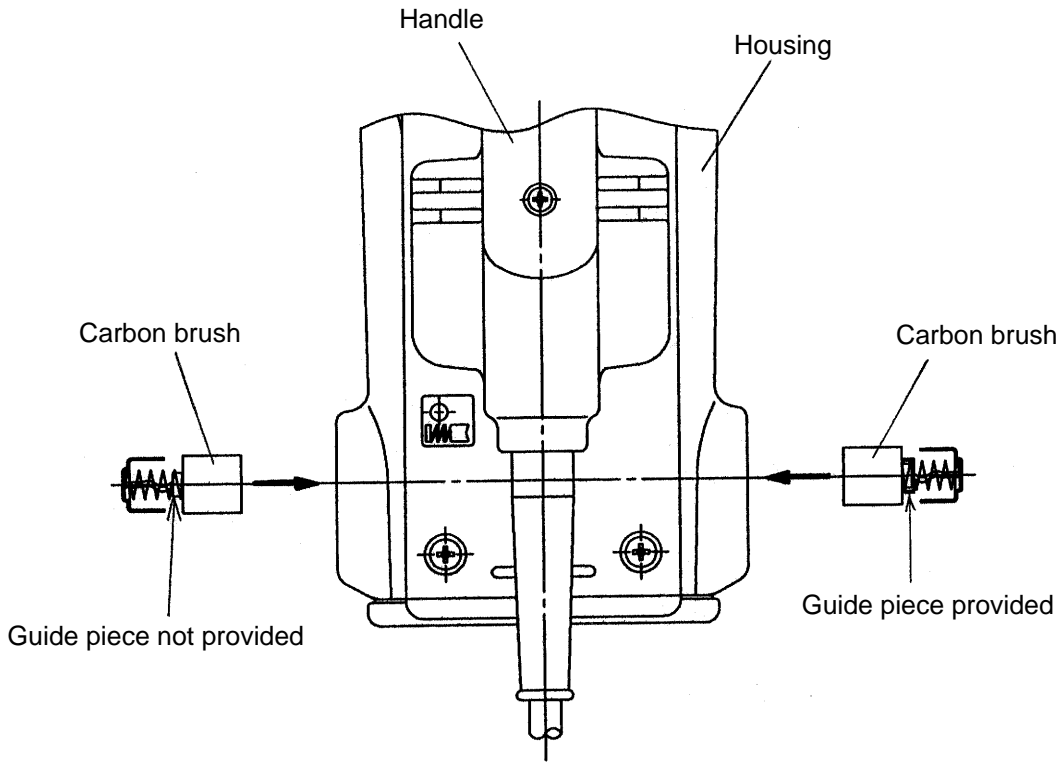

Fig. 21

9-3. Screw Locking Agent TB1401

Apply screw locking agent ThreeBond TB1401 to all of the M5 hexagon socket head bolts (except for M8 for front cover mounting and M6 hexagon socket head bolts for cylinder case mounting, which are special bolts to be treated as service parts).

(Note) Be sure to apply screw locking agent ThreeBond TB1401 to the threads during reassembly, as the bolts loosened with vibration may cause damage to the tool body.

9-4. Tightening Torque

9-4-1. Tightening torque of each screw

- M5 Hex. Socket Hd. Bolt $7.84^{+1.96}_0$ N•m (80^{+20}_0 kgf•cm, $69.4^{+17.4}_0$ in-lbs.)
- D4 Tapping Screw 2.0 ± 0.5 N•m (20 ± 5 kgf•cm, 17.4 ± 4.3 in-lbs.)
- D5 Tapping Screw 2.9 ± 0.49 N•m (30 ± 5 kgf•cm, 26.0 ± 4.3 in-lbs.)
- Bolt for mounting the side cover (M5 x 16 Flanged Bolt) 3.92 ± 0.49 N•m (40 ± 5 kgf•cm, 34.7 ± 4.3 in-lbs.)
- Bolt for mounting the crank case cover (M5 x 16 Flanged Bolt) 4.9 ± 0.98 N•m (50 ± 10 kgf•cm, 43.4 ± 8.7 in-lbs.)
- Bolt for mounting the housing (M6 x 40 Flanged Bolt) $4.9^{+1.96}_0$ N•m (50^{+20}_0 kgf•cm, $43.4^{+17.4}_0$ in-lbs.)
- Bolt for mounting the front cover (M8 x 25 Hex. Socket Hd. Bolt) 22.1 ± 4.9 N•m (225 ± 50 kgf•cm, 195.2 ± 43.4 in-lbs.)
- Bolt for mounting the cylinder case (M6 x 35 Flanged Bolt) $9.8^{+1.96}_0$ N•m (100^{+20}_0 kgf•cm, $86.8^{+17.4}_0$ in-lbs.)

9-5. Wiring Diagrams

- For products without noise suppressor

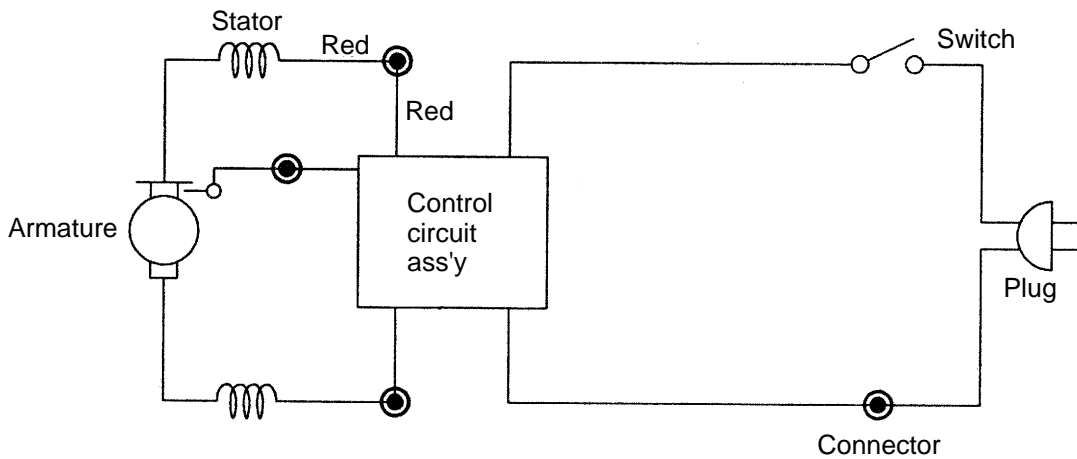

- For products with noise suppressor

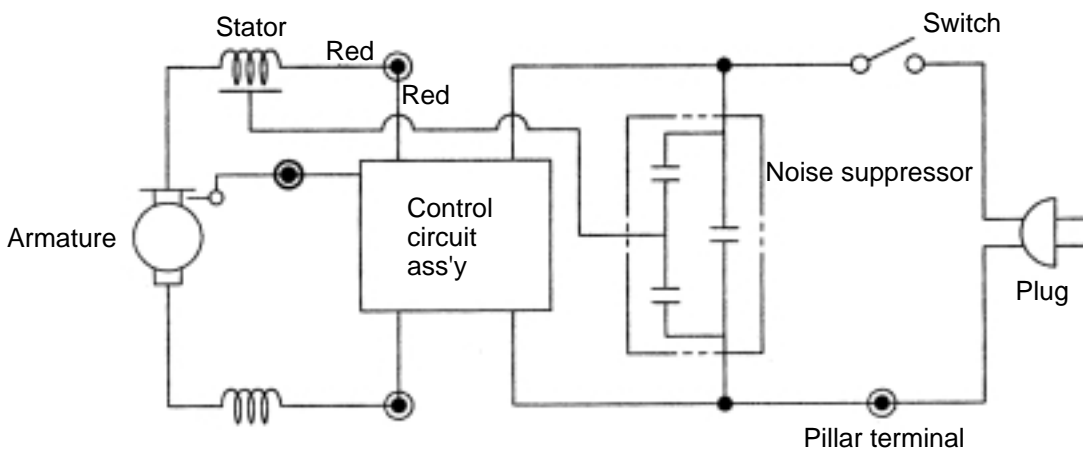

Fig. 22

9-6. Insulation Test

On completion of disassembly and repair, measure the insulation resistance and dielectric strength.

Insulation resistance : 7 MΩ or more with DC 500 V Megohm Tester

Dielectric strength : AC 4,000 V/1 minute, with no abnormalities 220 V – 240 V
(and 110 V for U.K. products)

AC 2,500 V/1 minute, with no abnormalities 110 V – 127 V

(except U.K. products)

9-7. No-Load Current Values

After no-load operation for 30 minutes, the no-load current values should be as follows.

Voltage	110 V	115 V	127 V	220 V	230 V	240 V
Current (A) Max.	6.8 A	6.5 A	5.9 A	3.4 A	3.3 A	3.2 A

10. STANDARD REPAIR TIME (UNIT) SCHEDULES

MODEL	Variable		10	20	30	40	50	60 min.
	Fixed							
DH 50MB		Work Flow						
		Handle Cover Switch (C) Cord Cord Armor					Seal Packing Gear Cover Needle Bearing	Housing Ass'y Stator Ass'y
		Tail Cover Ball Bearing (6201VV)					Armature Ass'y Ball Bearing (6203VV) Dust Washer Oil Seal Sleeve (B)	
		Crank Case Cover Rubber Seal						
		General Assembly						
					Handle Plug (A) Plug (B) Control Circuit Side Cover Ass'y		Crank Shaft Feather Key (5x5x15) Ball Bearing (6205) Bearing Cover First Gear Second Pinion	Crank Case
		Front Cap Grip Needle Holder Retainer Spring Spring Holder	Front Cover O-Ring x 2 Oil Seal Urethane Ring Ball Bearing (6008CM)				Bevel Pinion Key (3x3x8) Oil Seal (A) Ball Bearing (6202) Washer (A) Gear Holder Spring (C) Needle Pin Second Gear Spacer Ball Bearing (629VV)	
		O-Ring Lever Shaft Under Cover Shaft Cover Lever Spring Sleeve	Damper Damper Holder Urethane Ring Holder Sleeve Needle Roller Retainer Sleeve Second Hammer					
					Clutch Connecting Rod Ass'y Needle Bearing Piston Piston Pin Striker O-Ring		Needle Pin Cylinder O-Ring (D) Clutch Spring Lock Sleeve Lock Spring Cylinder Case Needle Bearing x 2 Bevel Gear Sleeve (A)	

Assembly Diagram for DH 50MB

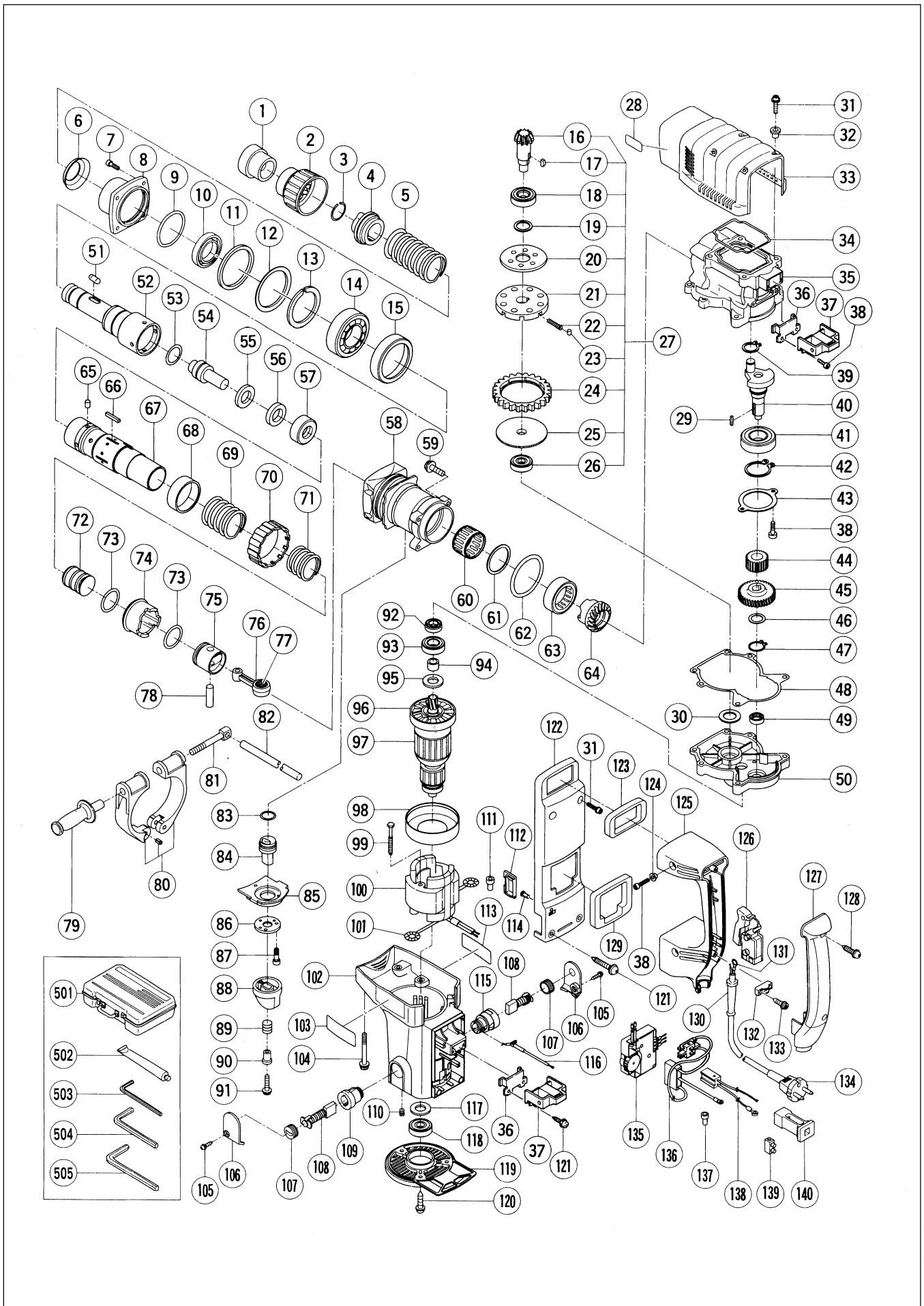

PARTS

DH 50MB

ITEM NO.	CODE NO.	DESCRIPTION	NO. USED	REMARKS
1	313-415	FRONT CAP	1	
2	318-608	GRIP	1	
3	318-590	STOPPER RING	1	
4	313-413	NEEDLE HOLDER	1	
5	313-419	RETAINER SPRING	1	
6	318-589	SPRING HOLDER	1	
7	880-810	NYLOCK HEX. SOCKET HD. BOLT M8X25	4	
8	318-587	FRONT COVER	1	
9	878-863	O-RING (S-70)	1	
10	318-588	OIL SEAL (NBR710)	1	
11	318-586	URETHANE RING	1	
12	318-585	URETHANE RING HOLDER	1	
13	318-582	RETAINING RING D40	1	
14	600-8CM	BALL BEARING 6008CM	1	
15	318-581	SLEEVE	1	
16	318-551	BEVEL PINION	1	
17	944-109	FEATHER KEY 3X3X8	1	
18	620-2DD	BALL BEARING 6202DDCMPS2L	1	
19	313-058	WASHER	1	
20	318-552	WASHER (A)	1	
21	318-554	GEAR HOLDER	1	
22	318-555	SPRING (C)	8	
23	313-057	NEEDLE PIN D6X6	8	
24	318-553	SECOND GEAR	1	
25	318-556	SPACER	1	
26	629-VVM	BALL BEARING 629VVC2PS2L	1	
27	318-550	SLIP CLUTCH ASS'Y	1	INCLUD.16-26
28		SDS-MAX LABEL	1	
29	945-072	FEATHER KEY 5X5X15	2	
30	944-525	BEARING WASHER (C)	1	
31	313-082	NYLOCK BOLT (W/FLANGE) M5X16	6	
32	991-711	DISTANCE PIECE (B)	4	
33	318-584	CRANK CASE COVER ASS'Y	1	INCLUD.32
34	313-084	RUBBER SEAL	1	
35	318-543	CRANK CASE	1	
36	980-750	GUIDE PLATE	2	
37	980-727	HANDLE RUBBER	2	
38	878-181	NYLOCK HEX. SOCKET HD. BOLT M5X16	8	
39	939-542	RETAINING RING FOR D12 SHAFT (10 PCS.)	1	
40	318-544	CRANK SHAFT	1	
41	620-5DD	BALL BEARING 6205DDCMPS2L	1	
42	965-469	RETAINING RING FOR D25 SHAFT	1	
43	318-548	BEARING COVER	1	
44	318-545	SECOND PINION	1	
45	318-546	FIRST GEAR	1	
46	318-547	THRUST WASHER	1	
47	967-261	RETAINING RING FOR D17 SHAFT	1	
48	318-549	SEAL PACKING	1	
49	939-299	NEEDLE BEARING (M661)	1	
50	318-595	GEAR COVER	1	
51	313-421	NEEDLE ROLLER D8X20	2	

PARTS

DH 50MB

ITEM No.	CODE NO.	DESCRIPTION	NO. USED	REMARKS	
52	318-580	RETAINER SLEEVE	1		
53	986-104	O-RING	1		
54	318-564	SECOND HAMMER	1		
55	318-565	DAMPER WASHER	1		
56	318-566	DAMPER	1		
57	318-567	DAMPER HOLDER	1		
58	318-568	CYLINDER CASE	1		
59	318-451	NYLOCK BOLT (W/FLANGE) M6X35	4		
60	318-560	NEEDLE BEARING	1		
61	981-973	CYLINDER WASHER	1		
62	985-779	O-RING (D)	1		
63	318-659	NEEDLE BEARING	1		
64	318-559	BEVEL GEAR	1		
65	313-057	NEEDLE PIN D6X6	4		
66	971-750	FEATHER KEY 3X3X20	2		
67	318-558	CYLINDER	1		
68	318-583	SLEEVE (A)	1		
69	318-563	LOCK SPRING	1		
70	318-562	LOCK SLEEVE	1		
71	318-631	CLUTCH SPRING	1		
72	318-630	STRIKER	1		
73	318-917	O-RING (FPM 710)	1		
74	318-561	CLUTCH	1		
75	985-772	PISTON	1		
76	318-557	CONNECTING ROD ASS'Y	1	INCLUD.77	
77	980-756	NEEDLE BEARING (NSK AJ50 1203)	1		
78	955-593	PISTON PIN	1		
79	318-574	SIDE HANDLE	1		
80	318-575	HANDLE HOLDER	1		
81	318-576	HANDLE BOLT	1		
82	971-786	STOPPER ROD	1		
83	873-095	O-RING (P-16)	1		
84	318-577	LEVER SHAFT	1		
85	318-578	UNDER COVER	1		
86	313-411	SHAFT COVER	1		
87	318-579	HEX.SOCKET HD.BOLT (W/WASHER) M4X12	2		
88	313-410	LEVER	1		
89	307-605	SPRING	1		
90	313-424	SLEEVE	1		
91	313-077	NYLOCK BOLT (W/FLANGE) M5X25	1		
92	318-596	OIL SEAL (FPM 707)	1		
93	620-3VV	BALL BEARING 6203VVCMP2L	1		
94	318-597	SLEEVE (B)	1		
95	318-594	DUST WASHER	1		
96	318-918	FAN	1		
*	97	360-520U	ARMATURE ASS'Y 110V-115V	1	INCLUD.93-96,117,118
*	97	360-520D	ARMATURE ASS'Y 120V-127V	1	INCLUD.96
*	97	360-520E	ARMATURE ASS'Y 220V-230V	1	INCLUD.96
*	97	360-520F	ARMATURE ASS'Y 240V	1	INCLUD.96
98	318-633	FAN GUIDE	1		
99	953-121	HEX. HD. TAPPING SCREW D5X50	2		

PARTS

DH 50MB

ITEM No.	CODE NO.	DESCRIPTION	NO. USED	REMARKS
*	100	340-463C	STATOR ASS'Y 110V-115V	1 INCLUD.101
*	100	340-463D	STATOR ASS'Y 120V-127V	1 INCLUD.101
*	100	340-463E	STATOR ASS'Y 220V-230V	1 INCLUD.101
*	100	340-463F	STATOR ASS'Y 240V	1 INCLUD.101
*	100	340-463G	STATOR ASS'Y 115V	1 INCLUD.101 FOR USA,CAN
	101	958-032	BRUSH TERMINAL	2
	102	318-607	HOUSING ASS'Y	1 INCLUD.109,110,115,116
	103		HITACHI LABEL	1
	104	318-570	NYLOCK BOLT (W/FLANGE) M6X40	6
	105	307-811	TAPPING SCREW (W/FLANGE) D4X16 (BLACK)	2
	106	318-599	BRUSH CAP COVER	2
	107	940-540	BRUSH CAP	2
	108	999-077	CARBON BRUSH (AUTO STOP TYPE) (1 PAIR)	2
	109	980-487	BRUSH HOLDER	1
	110	938-477	HEX. SOCKET SET SCREW M5X8	2
	111	959-141	CONNECTOR 50092 (10 PCS.)	3
	112	313-948	DIAL FRAME	1
	113		NAME PLATE	1
	114	318-632	PRISM	1
	115	318-593	BRUSH HOLDER	1
	116		PIECE	1
	117	944-954	BEARING WASHER	1
	118	620-1VV	BALL BEARING 6201VVCMP2L	1
	119	318-598	TAIL COVER	1
	120	303-273	TAPPING SCREW (W/FLANGE) D5X16	3
	121	305-558	TAPPING SCREW (W/FLANGE) D5X25 (BLACK)	4
	122	318-571	SIDE COVER ASS'Y	1 INCLUD.114.123.129
	123	318-572	HANDLE PACKING (A)	1
	124	991-711	DISTANCE PIECE (B)	4
	125	318-601	HANDLE	1
	126	313-093	SWITCH (C) (2P SCREW TYPE W/O LOCK)	1
	127	318-602	HANDLE COVER	1
	128	301-653	TAPPING SCREW (W/FLANGE) D4X20 (BLACK)	2
	129	318-573	HANDLE PACKING (B)	1
*	130	940-778	CORD ARMOR D10.7	1
*	130	958-049	CORD ARMOR D8.2	1
*	131	992-810	TERMINAL	1
*	131	980-063	TERMINAL	1 FOR SAF,AUS
*	131	930-804	TERMINAL M4.0 (10 PCS.)	1 FOR USA,CAN
*	132	960-266	CORD CLIP	1
*	132	981-987Z	CORD CLIP	1 FOR SUI
	133	984-750	TAPPING SCREW (W/FLANGE) D4X16	2
*	134	500-390Z	CORD	1 (CORD ARMOR D10.7)
*	134	500-446Z	CORD	1 (CORD ARMOR D10.7) FOR GBR(230V)
*	134	500-434Z	CORD	1 (CORD ARMOR D10.7) FOR USA,CAN
*	134	500-408Z	CORD	1 (CORD ARMOR D8.2) FOR AUS
*	134	500-391Z	CORD	1 (CORD ARMOR D10.7) FOR SUI
*	134	500-460Z	CORD	1 (CORD ARMOR D10.7) FOR GBR(110V)
*	135	318-605	CONTROLLER CIRCUIT	1
*	135	318-591	CONTROLLER CIRCUIT	1 FOR GBR(110V)
*	135	318-606	CONTROLLER CIRCUIT	1 FOR USA,CAN

* : ALTERNATIVE PARTS

1 - 00

STANDARD ACCESSORIES

DH 50MB

ITEM No.	CODE NO.	DESCRIPTION	NO. USED	REMARKS
501	318-646	CASE (PLASTIC)	1	
502	981-840	GREASE (A) FOR HAMMER.HAMMER DRILL (30G)	1	
503	944-458	HEX. BAR WRENCH 4MM	1	
504	944-459	HEX. BAR WRENCH 5MM	1	
505	872-422	HEX. BAR WRENCH 6MM	1	

OPTIONAL ACCESSORIES

ITEM No.	CODE NO.	DESCRIPTION	NO. USED	REMARKS
601	317-483	DRILL BIT (SDS MAX) D10.5X305	1	
602	317-484	DRILL BIT (SDS MAX) D12.5X305	1	
603	317-485	DRILL BIT (SDS MAX) D12.7X305	1	
604	317-486	DRILL BIT (SDS MAX) D14.3X305	1	
605	317-487	DRILL BIT (SDS MAX) D14.5X305	1	
606	313-448	DRILL BIT (SDS MAX) D16X340	1	
607	313-449	DRILL BIT (SDS MAX) D19X340	1	
608	313-450	DRILL BIT (SDS MAX) D22X320	1	
609	313-451	DRILL BIT (SDS MAX) D25X320	1	
610	313-452	DRILL BIT (SDS MAX) D28X370	1	
611	313-453	DRILL BIT (SDS MAX) D32X370	1	
612	313-454	DRILL BIT (SDS MAX) D38X370	1	
613	313-455	DRILL BIT (SDS MAX) D40X370	1	
614	313-456	DRILL BIT (SDS MAX) D16X540	1	
615	313-457	DRILL BIT (SDS MAX) D19X540	1	
616	313-458	DRILL BIT (SDS MAX) D22X520	1	
617	313-459	DRILL BIT (SDS MAX) D25X520	1	
618	313-460	DRILL BIT (SDS MAX) D28X570	1	
619	313-461	DRILL BIT (SDS MAX) D32X570	1	
620	313-462	DRILL BIT (SDS MAX) D38X570	1	
621	313-463	DRILL BIT (SDS MAX) D40X570	1	
622	944-460	TAPER SHANK DRILL BIT D11X100	1	
623	944-461	TAPER SHANK DRILL BIT D12.3X110	1	
624	993-038	TAPER SHANK DRILL BIT D12.7X110	1	
625	944-462	TAPER SHANK DRILL BIT D14.3X110	1	
626	944-500	TAPER SHANK DRILL BIT D14.5X110	1	
627	944-463	TAPER SHANK DRILL BIT D17.5X120	1	
628	313-464	TAPER SHANK ADAPTER ASS'Y (SDS MAX) NO.1	1	INCLUD.629
629	944-477	COTTER	1	
630	313-465	ADAPTER (SDS MAX) FOR SDS PLUS SHANK BIT	1	
631	955-994	CORE BIT 25MM	1	
632	955-995	CORE BIT 29MM	1	
633	955-996	CORE BIT 32MM	1	INCLUD.651
634	955-998	CORE BIT 35MM	1	INCLUD.652
635	956-000	CORE BIT 38MM	1	INCLUD.653
636	955-154	CORE BIT 45MM	1	INCLUD.654
637	959-706	CORE BIT 50MM	1	INCLUD.655
638	955-155	CORE BIT 54MM	1	INCLUD.656
639	959-707	CORE BIT 60MM	1	INCLUD.657
640	956-002	CORE BIT 64MM	1	INCLUD.658
641	959-708	CORE BIT 70MM	1	INCLUD.659

* : ALTERNATIVE PARTS

1 - 00

OPTIONAL ACCESSORIES

DH 50MB

ITEM No.	CODE NO.	DESCRIPTION	NO. USED	REMARKS	
642	959-709	CORE BIT 75MM	1	INCLUD.660	
643	955-157	CORE BIT 79MM	1	INCLUD.661	
644	956-004	CORE BIT 94MM	1	INCLUD.662	
645	959-710	CORE BIT 100MM	1	INCLUD.663	
646	955-159	CORE BIT 105MM	1	INCLUD.664	
647	956-006	CORE BIT 120MM	1	INCLUD.665	
648	956-728	CORE BIT 150MM	1	INCLUD.666	
649	318-531	GUIDE PLATE (FOR CORE BIT 25MM)	1		
650	318-532	GUIDE PLATE (FOR CORE BIT 29MM)	1		
651	955-997	GUIDE PLATE (FOR CORE BIT 32MM)	1		
652	955-999	GUIDE PLATE (FOR CORE BIT 35MM)	1		
653	956-001	GUIDE PLATE (FOR CORE BIT 38MM)	1		
654	955-166	GUIDE PLATE (FOR CORE BIT 45MM)	1		
655	950-475	GUIDE PLATE (FOR CORE BIT 50MM)	1		
656	955-167	GUIDE PLATE (FOR CORE BIT 54MM)	1		
657	950-476	GUIDE PLATE (FOR CORE BIT 60MM)	1		
658	956-003	GUIDE PLATE (FOR CORE BIT 64MM)	1		
659	950-477	GUIDE PLATE (FOR CORE BIT 70MM)	1		
660	950-478	GUIDE PLATE (FOR CORE BIT 75MM)	1		
661	955-168	GUIDE PLATE (FOR CORE BIT 79MM)	1		
662	956-005	GUIDE PLATE (FOR CORE BIT 94MM)	1		
663	950-479	GUIDE PLATE (FOR CORE BIT 100MM)	1		
664	955-169	GUIDE PLATE (FOR CORE BIT 105MM)	1		
665	956-007	GUIDE PLATE (FOR CORE BIT 120MM)	1		
666	956-743	GUIDE PLATE (FOR CORE BIT 150MM)	1		
667	318-530	CENTER PIN FOR CORE BIT D25-29	1		
668	956-009	CENTER PIN (B) 147L FOR CORE BIT D32-35	1		
669	955-165	CENTER PIN (A) 133L FOR CORE BIT D38-150	1		
670	313-466	CORE BIT SHANK (B) SDS MAX D25-35	1		
671	313-467	CORE BIT SHANK (A) SDS MAX D38-150	1		
672	950-272	DRILL CHUCK 13VLA	1	INCLUD.673	
673	930-515	CHUCK WRENCH 10G	1		
674	313-468	CHUCK ADAPTER (SDS MAX)	1		
675	313-469	CHEMICAL ANCHOR ADAPTER (SDS MAX) 12.7MM	1		
676	313-470	CHEMICAL ANCHOR ADAPTER (SDS MAX)19MM	1		
677	313-471	BULL POINT (SDS MAX) 280L	1		
678	313-472	BULL POINT (SDS MAX) 400L	1		
679	313-473	COLD CHISEL (SDS MAX) 280MM	1		
680	313-474	COLD CHISEL (SDS MAX) 400MM	1		
681	313-475	CUTTER (SDS MAX) W50X400L	1		
682	313-476	SCOOP (SDS MAX) 400L	1		
683	313-477	BUSHING TOOL (SDS MAX)	1		
684	313-478	RAMMER (SDS MAX) 150MM X 150MM	1		
685	313-479	SHANK (SDS MAX)FOR RAMMER,BUSHING TOOL	1		
686	944-575	SYRINGE	1		
687	318-085	SYRINGE (BELLOWS TYPE)	1		
688	308-471	GREASE FOR HAMMER.HAMMER DRILL (70G)	1		
689	980-927	GREASE FOR HAMMER.HAMMER DRILL (500G)	1		