

MODEL

DV 18DV

HITACHI
POWER TOOLS

**CORDLESS IMPACT DRILL
DV 18DV**

**TECHNICAL DATA
AND
SERVICE MANUAL**

D



LIST No. F854

Jul. 2001

SPECIFICATIONS AND PARTS ARE SUBJECT TO CHANGE FOR IMPROVEMENT

Notice for use

Specifications and parts are subject to change for improvement.

Refer to Hitachi Power Tool Technical News for further information.

REMARK:

Throughout this TECHNICAL DATA AND SERVICE MANUAL, a symbol(s) is(are) used in the place of company name(s) and model name(s) of our competitor(s). The symbol(s) utilized here is(are) as follows:

Symbols Utilized	Competitors	
	Company Name	Model Name
P	DEWALT	DW997
C	MAKITA	8443D

CONTENTS

	Page
1. PRODUCT NAME	1
2. MARKETING OBJECTIVE	1
3. APPLICATIONS	1
4. SELLING POINTS	1
4-1. Selling Point Descriptions	2
5. SPECIFICATIONS	3
6. COMPARISONS WITH SIMILAR PRODUCTS	4
7. WORKING PERFORMANCE PER SINGLE CHARGE	5
8. PRECAUTIONS IN SALES PROMOTION	6
8-1. Safety Instructions	6
8-2. Inherent Drawbacks of Cordless Impact Drills Requiring Particular Attention during Sales Promotion	8
9. REFERENCE MATERIALS	9
9-1. Speed Control Mechanism	9
10. REPAIR GUIDE	10
10-1. Precautions in Disassembly and Reassembly	10
10-2. Precautions in Disassembly and Reassembly of Battery Charger	17
11. STANDARD REPAIR TIME (UNIT) SCHEDULES	18
Assembly Diagram for DV 18DV	

1. PRODUCT NAME

Hitachi 18 V Cordless Impact Drill, Model DV 18DV

2. MARKETING OBJECTIVE

European competitors are now preparing to have a wide selection of cordless impact drills (combination drills), and it is expected that cordless impact drills will be the growing segment of the power tool industry.

The Model DV 18DV cordless impact drill has been newly developed as a higher level version of the Model DV 14DV (14.4 V product) that is brought out together with the Model DV 18DV. The Model DV 18DV is equipped with the T-type handle and the 22-step clutch for easier operation as a driver drill.

3. APPLICATIONS

- Tightening and loosening wood screws, self-tapping screws and machine screws
- Drilling into wood materials, plastic, mild steel and aluminum
- Drilling into brick and concrete block

4. SELLING POINTS

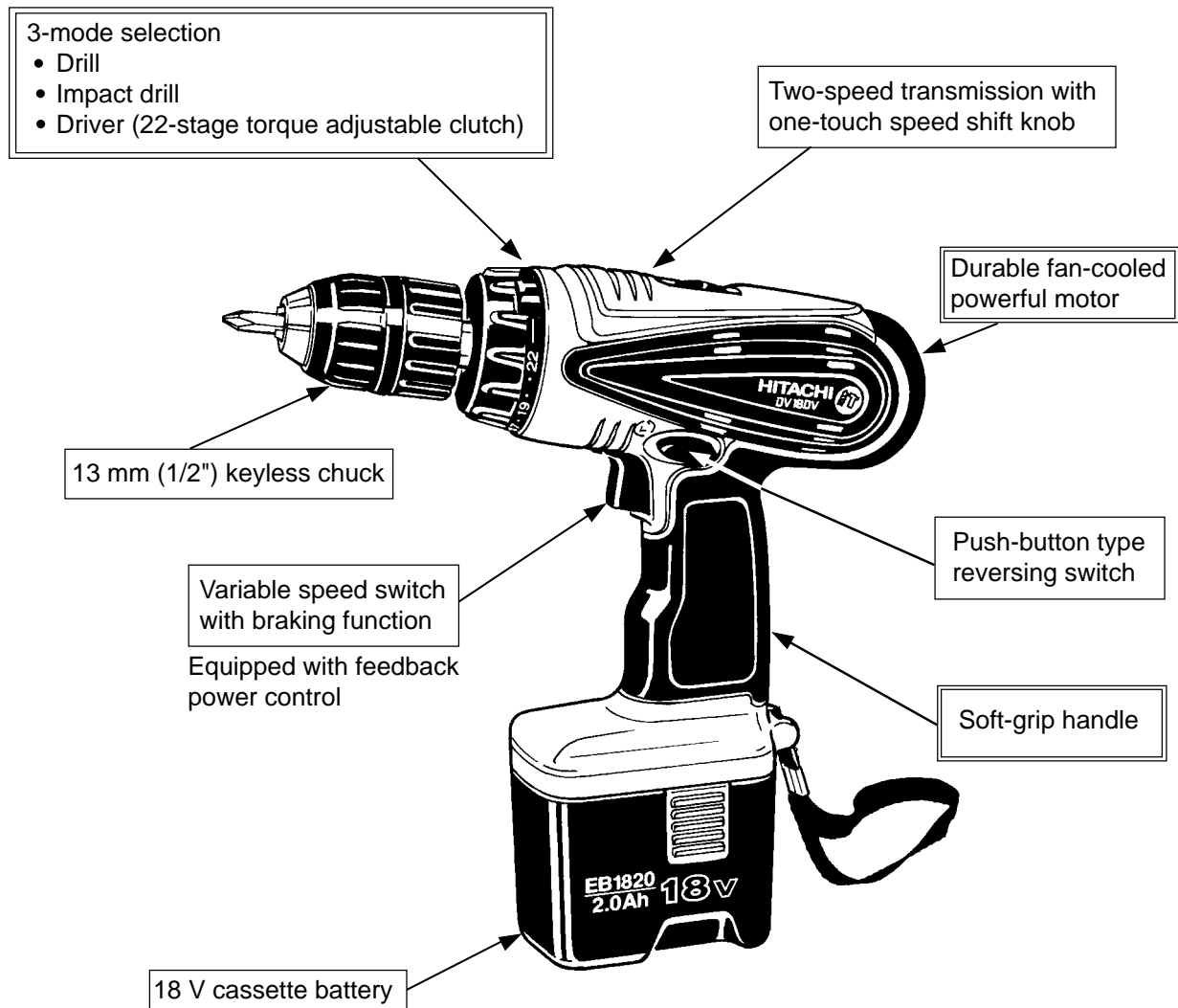

4-1. Selling Point Descriptions

4-1-1. 3-mode selection

This model can be easily switched between three modes, screwdriving, drilling and impact drilling, by simply turning the cap dial. To use it as a screwdriver, set the cap to any position between 1 and 22, depending on the types of screws and the material to be fastened. The clutch is then engaged to adjust the tightening force among the corresponding twenty-two torque levels.

In order to fasten large diameter wood screws or drill into metal, wood and plastic, align the cap's drill mark "◀" with the triangle mark on the main body. The clutch is then directly coupled to provide the maximum power output. Drilling into very hard materials such as brick and concrete block can be efficiently carried out by aligning the cap impact mark "⊞" with the triangle mark on the main body. (See Fig. 1.)

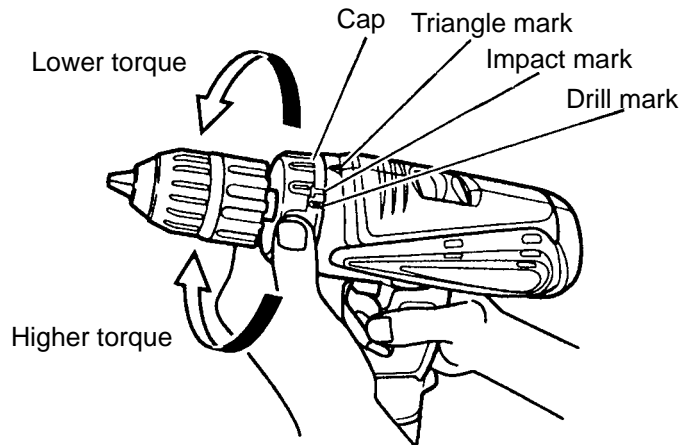

Fig. 1

4-1-2. Durable fan-cooled powerful motor

The cooling fan incorporated in the motor and the air vents provided in its outer frame greatly enhance the cooling effect, ensuring improved durability in continuous operation.

4-1-3. 13 mm (1/2") keyless chuck

The keyless chuck facilitates fast and easy replacement of driver bits. Replacement can be carried out simply by holding the ring with one hand, while turning the sleeve with the other hand.

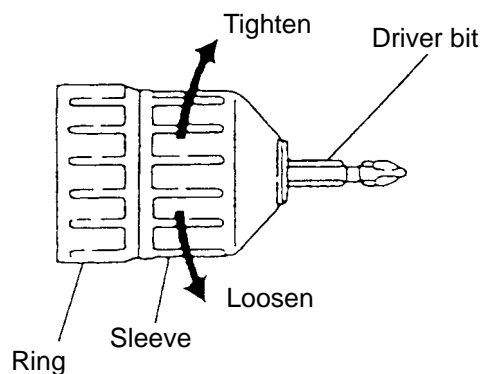

Fig. 2

4-1-4. Variable speed switch with braking function

The braking function allows the driver unit to stop rotation immediately when the trigger switch is released, which is a convenient feature during actual working. Also, the feedback system ensures a sufficiently large torque even in the variable speed range.

5. SPECIFICATIONS

Capacity	Screwdriver Machine screw6 mm (1/4") Wood screw8 mm dia. x 75 mm (#20 x 3") Brick 16 mm (5/8") [Depth 30 mm (1-1/4")] Drill MetalMild steel 13 mm (1/2") [Thickness 1.6 mm (1/16")] Aluminum 13 mm (1/2") [Thickness 1.6 mm (1/16")] Wood38 mm (1-1/2") [Thickness 18 mm (11/16")]																						
Keyless chuck (13VLRN-N)	Mount typeScrew-on (UNF 1/2" - 20) Diameter1.5 - 13 mm (1/16" - 1/2")																						
Rotation speed (No-load)	Low: 0 - 400/min. High: 0 - 1,500/min.																						
Impact rate (No-load)	Low: 0 - 6,000/min. High: 0 - 22,500/min.																						
Type of motor	DC magnet motor																						
Torque	Slip torque 1.0 - 5.9 N·m (10 - 60 kgf·cm, 9 - 52 in-lbs.) [22 stages] Max. torque High: 11 N·m (110 kgf·cm, 96 in-lbs.) Low: 45 N·m (460 kgf·cm, 400 in-lbs.)																						
Type of switch	Trigger switch with push button for forward and reverse rotation changeover (w/o stopper)																						
Handle configuration	T-type																						
Enclosure	Body Glassfiber reinforced polycarbonate resin (green) and thermoplastic elastomer (black) Battery Glassfiber reinforced polyamide resin (black) Charger ABS resin (black)																						
Battery (Type EB 1814/EB 1820)	Sealed cylindrical nickel-cadmium storage battery Nominal voltage DC 18 V Nominal life Charging/discharging: Approx. 500/1,000 times (in case of Model UC 24YFA) Nominal capacity 1.4/2.0 Ah																						
Battery (Type EB18H/EB 1830H)	Sealed cylindrical nickel-metal-hydride storage battery Nominal voltage DC 18 V Nominal life Charging/discharging: Approx. 500 times (in case of Model UC 24YFA) Nominal capacity 2.2/3.0 Ah																						
Charger (Model UC 24YFA)	Overcharge protection system: (1) Battery voltage detection (Δ^2V system) (2) Battery surface temperature detection (thermostat or thermistor) (3) 120 minutes timer Power input: 90 W Charging time: Approx. 40 minutes [for type EB 1814 battery at 20°C (68°F)] Approx. 50 minutes [for type EB 1820 battery at 20°C (68°F)] Approx. 55 minutes [for type EB 18H battery at 20°C (68°F)] Approx. 70 minutes [for type EB 1830H battery at 20°C (68°F)] Operable ambient temperature range: 0°C - 40°C (32°F - 104°F) The maximum allowable temperature of the type EB 1814 or EB 1820 battery is 60°C (140°F) and the type EB18H or EB 1830H battery is 45°C (113°F). Indication method of battery charging function:																						
	<table border="1" style="width: 100%; border-collapse: collapse;"> <thead> <tr> <th colspan="4" style="text-align: center;">Indications of the pilot lamp</th> </tr> </thead> <tbody> <tr> <td style="width: 15%;">Before charging</td> <td style="width: 15%;">Blinks (RED)</td> <td style="width: 50%;">Lights for 0.5 seconds. Does not light for 0.5 seconds. (off for 0.5 seconds)</td> <td rowspan="3" style="width: 20%;"></td> </tr> <tr> <td>While charging</td> <td>Lights (RED)</td> <td>Lights continuously</td> </tr> <tr> <td>Charging complete</td> <td>Blinks (RED)</td> <td>Lights for 0.5 seconds. Does not light for 0.5 seconds. (off for 0.5 seconds)</td> </tr> <tr> <td>Charging impossible</td> <td>Flickers (RED)</td> <td>Lights for 0.1 seconds. Does not light for 0.1 seconds. (off for 0.1 seconds)</td> <td>Malfunction in the battery or the charger</td> </tr> <tr> <td>Charging impossible</td> <td>Lights (GREEN)</td> <td>Lights continuously</td> <td>The battery temperature is high, making recharging impossible.</td> </tr> </tbody> </table>	Indications of the pilot lamp				Before charging	Blinks (RED)	Lights for 0.5 seconds. Does not light for 0.5 seconds. (off for 0.5 seconds)		While charging	Lights (RED)	Lights continuously	Charging complete	Blinks (RED)	Lights for 0.5 seconds. Does not light for 0.5 seconds. (off for 0.5 seconds)	Charging impossible	Flickers (RED)	Lights for 0.1 seconds. Does not light for 0.1 seconds. (off for 0.1 seconds)	Malfunction in the battery or the charger	Charging impossible	Lights (GREEN)	Lights continuously	The battery temperature is high, making recharging impossible.
Indications of the pilot lamp																							
Before charging	Blinks (RED)	Lights for 0.5 seconds. Does not light for 0.5 seconds. (off for 0.5 seconds)																					
While charging	Lights (RED)	Lights continuously																					
Charging complete	Blinks (RED)	Lights for 0.5 seconds. Does not light for 0.5 seconds. (off for 0.5 seconds)																					
Charging impossible	Flickers (RED)	Lights for 0.1 seconds. Does not light for 0.1 seconds. (off for 0.1 seconds)	Malfunction in the battery or the charger																				
Charging impossible	Lights (GREEN)	Lights continuously	The battery temperature is high, making recharging impossible.																				
Weight	Main body unit (including battery) 2.4 kg (5.3 lbs.) Charger unit (including cord) 0.6 kg (1.3 lbs.) Gross with charger and case 5.8 kg (12.9 lbs.)																						
Standard accessories	Charger (UC 24YFA) 1 Battery 1 Phillips (plus) driver bit (No. 2) 1 Case 1																						

6. COMPARISONS WITH SIMILAR PRODUCTS

Maker		HITACHI	P	C	
Model		DV 18DV			
Max. capacity	Drilling	Brick	16 mm (5/8")	16 mm (5/8")	16 mm (5/8")
		Mild steel	13 mm (1/2")	13 mm (1/2")	13 mm (1/2")
		Aluminum	13 mm (1/2")	Not indicated	Not indicated
		Soft wood	38 mm (1-1/2")	38 mm (1-1/2")	38 mm (1-1/2")
	Screw driving	Machine screw	6 mm (1/4")	Not indicated	Not indicated
		Wood screw	8 mm dia. x 75 mm length (#20 x 3")	Not indicated	Not indicated
Rotation speed	Low	0 – 400 /min	0 – 600 /min	0 – 450 /min	
	High	0 – 1,500 /min	0 – 1,800 /min	0 – 1,400 /min	
Impact rate	Low	0 – 6,000 /min	0 – 7,150 /min	0 – 6,750 /min	
	High	0 – 22,500 /min	0 – 20,350 /min	0 – 21,000 /min	
Drill chuck	Type	Keyless	Keyless	Keyless	
	Capacity	13 mm (1/2")	13 mm (1/2")	13 mm (1/2")	
Motor		DC magnet motor	DC magnet motor	DC magnet motor	
2-speed transmission		Gear changeover type 2-speed transmission			
Electric brake		Equipped	Equipped	Equipped	
Slip torque		1.0 – 5.9 N•m (10 – 60 kgf•cm) (9 – 52 in-lbs.) [22 positions]	Not indicated [15 positions]	Not indicated [16 positions]	
Max. torque	Low	45 N•m (460 kgf•cm) (400 in-lbs.)	37 N•m (377 kgf•cm) (325 in-lbs.)	45 N•m (460 kgf•cm) (400 in-lbs.)	
	High	11 N•m (110 kgf•cm) (96 in-lbs.)	Not indicated	Not indicated	
Battery	Nominal capacity	1.4 /2.0/2.2/3.0 Ah	2.0 Ah	2.0/2.6/3.0Ah	
	Nominal voltage	18 V	18 V	18 V	
	Charging time*	40/50/55/70 minutes	60 minutes	60/75/90 minutes	
Battery mount		Cassette type	Cassette type	Cassette type	
Overall length		255 mm (10-3/64")	262 mm (10-5/16")	267 mm (10-33/64")	
Weight		2.4 kg (5.3 lbs.)	2.5 kg (5.6 lbs.)	2.6 kg (5.7 lbs.)	

Remarks* Charging time varies depending on the type of charger to be used.

7. WORKING PERFORMANCE PER SINGLE CHARGE

Drilling and fastening performance comparison per charge

Type of work	Maker	Model	Working capacity (*1)						Drilling speed (sec./pc.)
			*0	*200	*400	*600	*800	*1000	
<p>Brick D30 mm (1-1/4") 10 mm dia. (3/8") Drill bit for concrete <High speed></p>	HITACHI	DV 18DV			150				3.3
		P			150				4.4
		C			110				5.3
<p>Mild steel T1.6 (1/16") 10 mm dia. (5/16") HSS drill bit <High speed></p>	HITACHI	DV 18DV		95					7.1
		P		100					8.2
		C		85					8.0
<p>American pine T18 (1 1/16") 36 mm dia. (1 3/32") Wood boring <Low speed></p>	HITACHI	DV 18DV		120					3.8
		P		140					3.8
		C		95					4.7
<p>American pine 75 mm (3") 8 mm dia. (#20) Wood screw A 5 mm-dia. prepared hole is provided. <Low speed></p>	HITACHI	DV 18DV		55					5.4
		P		60					5.1
		C		50					5.3
<p>Machine screw 12 mm (15/32") 6 mm (1/4") <High speed></p>	HITACHI	DV 18DV					*950		0.5
		P			*550				0.6
		C			*530				0.6

Remarks* Number of machine screws fastened per charge

Remarks*1 Number of holes or fasteners per charge

The above table shows an example of test data obtained by using a 2.0 Ah battery.

As actually measured values listed in the above table may vary depending on the sharpness of the drill bit, workpiece hardness (particularly in wood materials), moisture content of wood, charging condition, operator skill, etc. This data should be used as a comparative guide only.

8. PRECAUTIONS IN SALES PROMOTION

8-1. Safety Instructions

In the interest of promoting the safest and most efficient use of the Model DV 18DV Cordless Impact Drill by all of our customers, it is very important that at the time of sale, the salesperson carefully ensures that the buyer seriously recognizes the importance of the contents of the Handling Instructions, and fully understands the meaning of the precautions listed on the Caution Plate and Name Plate attached to each tool.

A. Handling instructions

Salespersons must be thoroughly familiar with the contents of the Handling Instructions in order to give pertinent advice to the customer. In particular, they must have a thorough understanding of the precautions for use of the cordless tools which are different from those of ordinary electric power tools.

(1) Before use, ensure that the unit is fully charged.

New units are not fully charged. Even if the units were fully charged at the factory, long periods of inactivity, such as during shipping, cause the storage battery to lose its charge. Customers must be instructed to fully charge the unit prior to use.

(2) Connect the charger to an AC power outlet only.

Use of any other power source (DC outlet, fuel powered generator, etc.) will cause the charger to overheat and burn out.

(3) Do not use any voltage increasing equipment (transformer, etc.) between the power source and the charger.

If the charger is used with voltage higher than that indicated on the unit, it will not function properly.

(4) Conduct battery charging at an ambient temperature range of 0 °C – 40 °C (32 °F – 104 °F).

Special temperature sensitive devices are employed in the charger to permit rapid charging. Ensure that customers are instructed to use the charger at the indicated ambient temperature range. At temperature under 0 °C (32 °F) the thermostat will not function properly, and the storage battery may be overcharged. At temperature over 40 °C (104 °F), the storage battery cannot be sufficiently charged. The optimum temperature range is 20 °C – 25 °C (68 °F – 77 °F).

(5) The battery charger should not be used continuously.

At high ambient temperature, if over three storage batteries are charged in succession, the temperature of the coils on the transformer will rise and there is a chance that the temperature fuse inserted in the interior of the transformer will inadvertently melt. After charging one battery, please wait about 15 minutes before charging the next battery.

(6) Do not insert foreign objects into the air vents on the charger.

The charger case is equipped with air vents to protect the internal electronic components from overheating. Caution the customer not to allow foreign materials, such as metallic or flammable objects, to be dropped or inserted into the air vents. This could cause electrical shock, fire, or other serious hazards.

(7) Do not attempt to disassemble the storage battery or the charger.

Special devices, such as a thermostat, are built into the storage battery and charger to permit rapid charging. Incorrect parts replacement and/or wiring will cause malfunctions which could result in fire or other hazards. Instruct the customer to bring these units to an authorized service center in the event repair or replacement is necessary.

(8) Disposal of the Type EB 1814, EB 1820, EB 18H or EB 1830H storage battery

Ensure that all customers understand that Type EB 1814, EB 1820, EB 18H or EB 1830H storage battery should be returned to the Hitachi power tool sales outlet or the authorized service center when it is no longer capable of being recharged or repaired. If thrown into a fire, the battery may explode, or, if discarded indiscriminately, leakage of the cadmium compound contained in the battery may cause environmental pollution.

B. Caution plates

(1) The following cautions are listed on the Name Plate attached to the main body of each tool.

For the U.S.A. and Canada

Warning

- To reduce the risk of injury, user must read and understand Instruction Manual.

AVERTISSEMENT

- Afin de réduire le risque de blessures, l'utilisateur doit lire et bien comprendre le mode d'emploi.

(2) The following cautions are listed on the Name Plate attached to each Type EB 1814, EB 1820, EB 18H or EB 1830H Storage Battery.

For Europe

- CAUTION**
- Read thoroughly HANDLING INSTRUCTIONS before use.
 - Do not disassemble nor throw into fire.

For the U.S.A.

- CAUTION**
- For safe operation, see Instruction Manual.
 - Use HITACHI charger UC 24YFA for recharging.

(3) The following cautions are listed on the Name Plate attached to the Model UC 24YFA charger.

For the U.S.A and Canada

CAUTION

- For safe operation, see Instruction Manual.
- Charge HITACHI rechargeable batteries types EB 7, EB 9, EB 12, EB 14, EB 18 series and EB 24B. Other types of batteries may burst causing personal injury and damage.
- Charge between 32 and 104 °F.
- Indoor use only.
- Replace defective cord immediately.

8-2. Inherent Drawbacks of Cordless Impact Drills Requiring Particular Attention during Sales Promotion

The cordless impact drill offers many advantages; it can be used in places where no power source is available, the absence of a cord allows easy use, etc. However, any cordless tool has certain inherent drawbacks.

Salespersons must be thoroughly familiar with these drawbacks in order to properly advise the customer in the most efficient use of the tool.

A. Suggestions and precautions for the efficient use of the tool

- (1) Use the Cordless Impact Drill for comparatively light work.

Because they are battery driven, the output of the motor in cordless impact drills is rather low in comparison with conventional electric power tools. Accordingly, they are not suitable for continuous drilling of many holes in succession, or for drilling into particularly hard materials which creates a heavy load. Salespersons should recommend conventional electric power tools for such heavy work.

- (2) Drilling of large diameter holes should be conducted at low speed.

Instruct the customer that drilling of large diameter holes or other work which requires particularly strong torque should be done at low speed. Because there is less torque at high speed, attempting such work at high speed will not improve working efficiency.

- (3) Do not insert a foreign object into body vent holes.

The body of this tool has vent holes for improving the cooling efficiency. As a fan is built into the motor, a foreign object inserted through a vent hole may cause a failure. Please instruct customers to never insert a foreign object into the vent hole.

- (4) Use a thrust of 100 to 150 N (10 – 15 kgf, 22 – 33 lbs).

It would not accelerate the drilling speed of this unit to press the tool strongly against the workpiece as is done with a usual AC impact drill. It would instead damage the drill bit, resulting not only in a poorer working efficiency but could also cause burning out of the motor.

- (5) Avoid "locking" of the motor.

Locking of the motor will cause an overload current that could result in burning of the motor and/or rapid deterioration of the battery. Salespersons should advise the customer to immediately release the switch and stop operation if the motor becomes locked. (A jammed drill bit can be disengaged from the workpiece material by setting the switch to reverse rotation, or by manually turning the main body of the tool.)

- (6) Variation in amount of work possible per charge

Although the nominal chargeable capacity of the storage batteries used with the Model DV 18DV is 1.4 Ah, 2.0 Ah, 2.2 Ah or 3.0 Ah, the actual capacity may vary within 10% of that value depending on the ambient temperature during use and charging, and the number of times the batteries have been recharged. It should be noted that other factors which may have a bearing on the amount of work possible per charge are the working conditions (ambient temperature, type and moisture content of the workpiece, sharpness of the drill bit, etc.) and the operational skill of the user.

(7) Precautions in the use of HSS Drill Bits

Although the Model DV 18DV is designed for drilling capacities of 38 mm (1-1/2") in wood, and 13 mm (1/2") in aluminum and mild steel, this capability is not as efficient as conventional electric power tools. In particular, when drilling through aluminum material with a 13 mm (1/2") drill bit, the drill tends to become locked when the drill bit penetrates through the material. For this reason, the customer should be cautioned to reduce the thrust on the main body of the drill when drilling completely through the material to avoid locking the tool. Repeated locking of the drill causes excessive current flow from the batteries which not only decreases the amount of work possible per charge, but could also result in burning of the motor.

B. Suggestions and precautions for the efficient use of the charger and storage batteries

If any of the storage batteries Types EB 1814, EB 1820, EB 18H and EB 1830H is exposed to direct sunlight for an extended period or if the temperature of the battery is high immediately after it has been used in the tool, the pilot lamp (red) may not be turned on when the battery is connected to the charger. Chargeable temperature ranges of each type of battery are specified as follows.

Types EB 1814 and EB 1820: from -5°C to 60°C (from 23°F to 140°F)

Types EB 18H and EB 1830H: from 0°C to 45°C (from 32°F to 113°F)

In such a case, the customer should be advised to place the battery in a shaded area with a good airflow, and allow sufficient cooling before recharging. This phenomenon is common to all existing batteries that employ a thermostat. The cooling time required before charging varies from a few minutes to about 30 minutes, depending on the load, duration of use, and ambient temperature.

9. REFERENCE MATERIALS

9-1. Speed Control Mechanism

Spindle rotation speed of the Model DV 18DV can be controlled by simply varying the amount by which the trigger switch is depressed. The relationship between the amount the trigger switch is depressed (in millimeters) and the rotation speed is illustrated in Fig. 3.

Note: The gradient and values illustrated in Fig. 3 are intended for reference only, and will vary slightly due to differences in the discharge condition of the battery, the ambient temperature, and individual speed-control element accuracy.

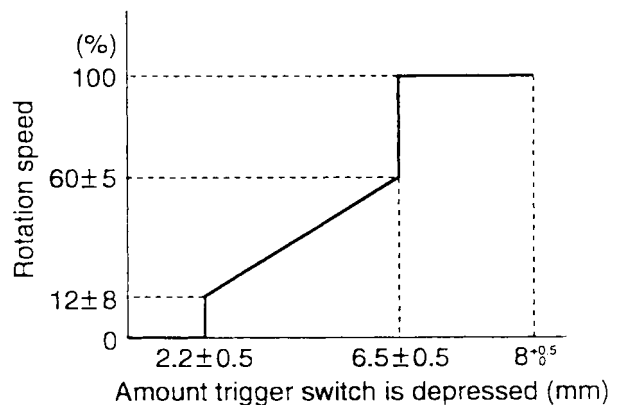

Fig. 3

10. REPAIR GUIDE

Be sure to remove the storage batteries from the main body before servicing. Inadvertent triggering of the switch with the storage battery connected will result in a danger of accidental turning of the motor.

10-1. Precautions in Disassembly and Reassembly

The **[Bold]** numbers in the description below correspond to the item numbers in the Parts List and exploded assembly diagram for the Model DV 18DV.

10-1-1. Disassembly

(1) Removal of the Drill Chuck 13VLRN-N (W/O Chuck Wrench) **[2]** (See Fig. 4.)

Remove the Drill Chuck 13VLRN-N (W/O Chuck Wrench) **[2]** of the fully assembled main body in accordance with the following procedures.

- (a) Fully open the jaws of the Drill Chuck 13VLRN-N (W/O Chuck Wrench) **[2]**, and turn the Special Screw (Left Hand) M6 x 23 **[1]** clockwise and remove it. Take care that it is left-hand threaded.
- (b) Fix the hexagonal bar wrench M10 into the Drill Chuck 13VLRN-N (W/O Chuck Wrench) **[2]** as indicated in Fig.4. Next, apply the Wrench 14 mm (special repair tool, Code No. 873929) **[601]** to the flat surfaces on the spindle to hold it steady, and remove it by turning counterclockwise. If it is difficult to loosen, use a pipe extension or similar tool.

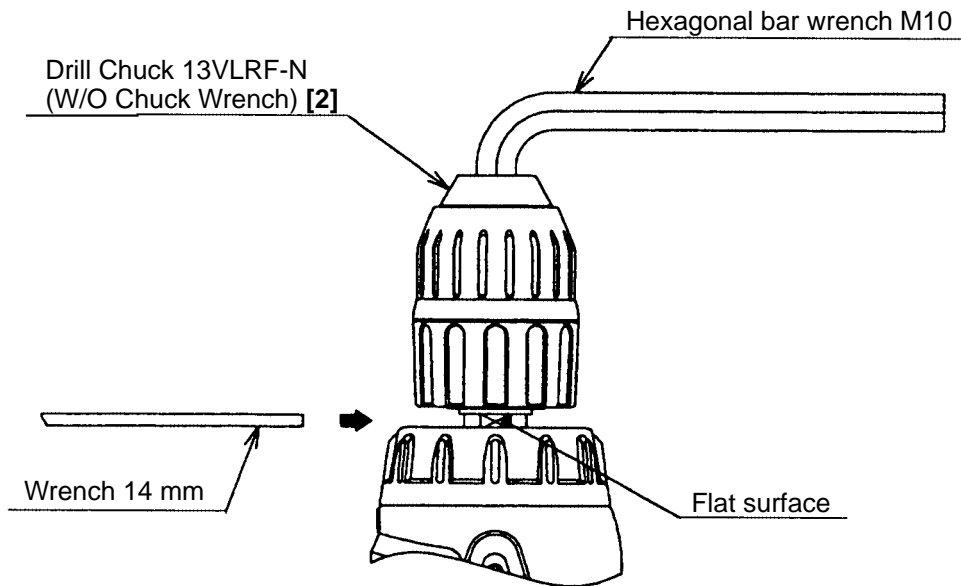

Fig. 4

(2) Removal of Housing (A). (B) Set **[35]**

First, align the drill mark " \triangle" on the Cap **[4]** with the triangle mark on Housing (A). (B) Set **[35]**.

Remove the eight Tapping Screws (W/Flange) D3 x 16 (Black) **[32]** secured to the main body. Gently open Housing (A). (B) Set **[35]** while holding their battery loading sections.

(3) After Housing (B) **[35]** has been removed, all the internal parts, assembled or separate, can be taken out as they are. Lift the entire contents from Housing (A) **[35]** while holding the Motor **[31]** and the Cap **[4]**.

(4) Disassembly of the gear unit

- (a) Remove the Cap [4] from the Front Case [12]. Take care not to remove the Switch Plate [8] and the Nut [9] from the Front Case [12] in this operation.
- (b) Turn the Motor [31] counterclockwise when viewed from the rear and remove it from the Rear Case [20].
- (c) Remove the Shift Arm [22] from the Rear Case [20], and remove the Shift Knob [41] from the Shift Arm [22].
- (d) Remove the Screw Set M3 x 12 (4 pcs.) [21] connecting the Front Case [12] and the Rear Case [20].
- (e) Remove Washer (A) [19], Planet Gear (C) Set (3 pcs.) [18], Carrier [17], Ring Gear [16], Spacer Washer [15], six Steel Balls D5 [14] and six Rollers [13] in sequence from the Front Case [12]. Take care not to lose the six Steel Balls D5 [14] and the six Rollers [13] in this operation.

(5) Removal of the Switch Plate [8]

Turn the switch flange so as to fit the projection of the switch flange to the recess of the Switch Plate [8], then remove the Switch Plate [8] from the Front Case [12]. (See Fig. 5.)

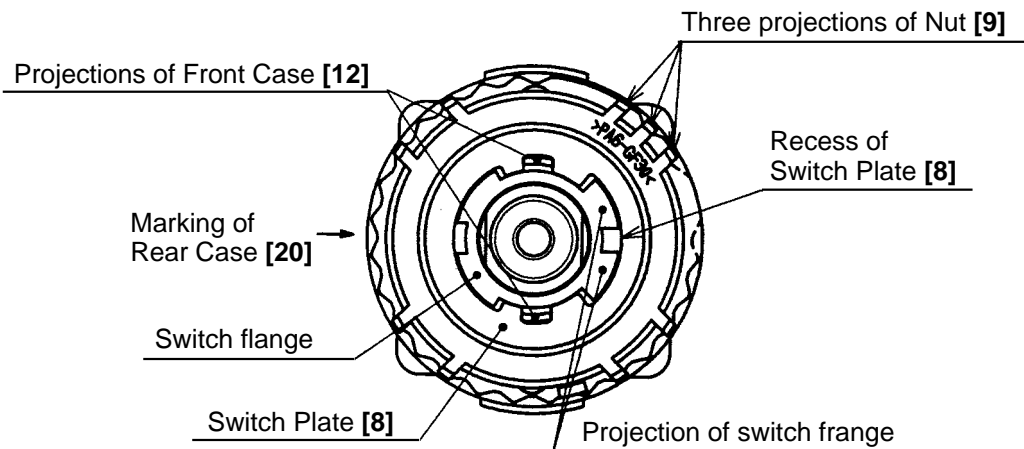

Fig. 5

(6) Removal of the Spring [10] and the Thrust Washer [11]

Turn the Nut [9] counterclockwise and remove it from the Front Case [12], then remove the Spring [10] and Thrust Washer [11] from the Front Case [12].

(Note) Do not disassemble the Front Case [12].

(7) Removal of the O-ring [6]

Pull out the Lock Washer [7] from the Cap [4] and remove the O-ring [6]. (See Fig. 6.)

(8) Disassembly of the power supply unit

(Note) Do not remove the fin secured to the DC-speed Control Switch [38] with a screw.

Remove the two Machine Screws (W/SP. Washer) M4 x 6 [34], and take the Motor [31] and the Motor Spacer [30] apart.

Disconnect the Internal Wires (Black) [36] and (Red) [37] from the Motor [31] with a soldering iron, then disconnect them from the DC-speed Control Switch [38] with a soldering iron in the same manner.

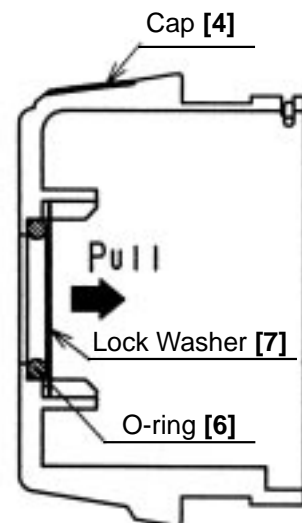

Fig. 6

10-1-2. Reassembly

Reassembly can generally be carried out as the reverse of the disassembly procedure, with some items to be noted as follows.

(1) Reassembly of the power supply unit

(a) Be sure to perform wiring connections as indicated in the wiring diagram. (See Fig. 7.)

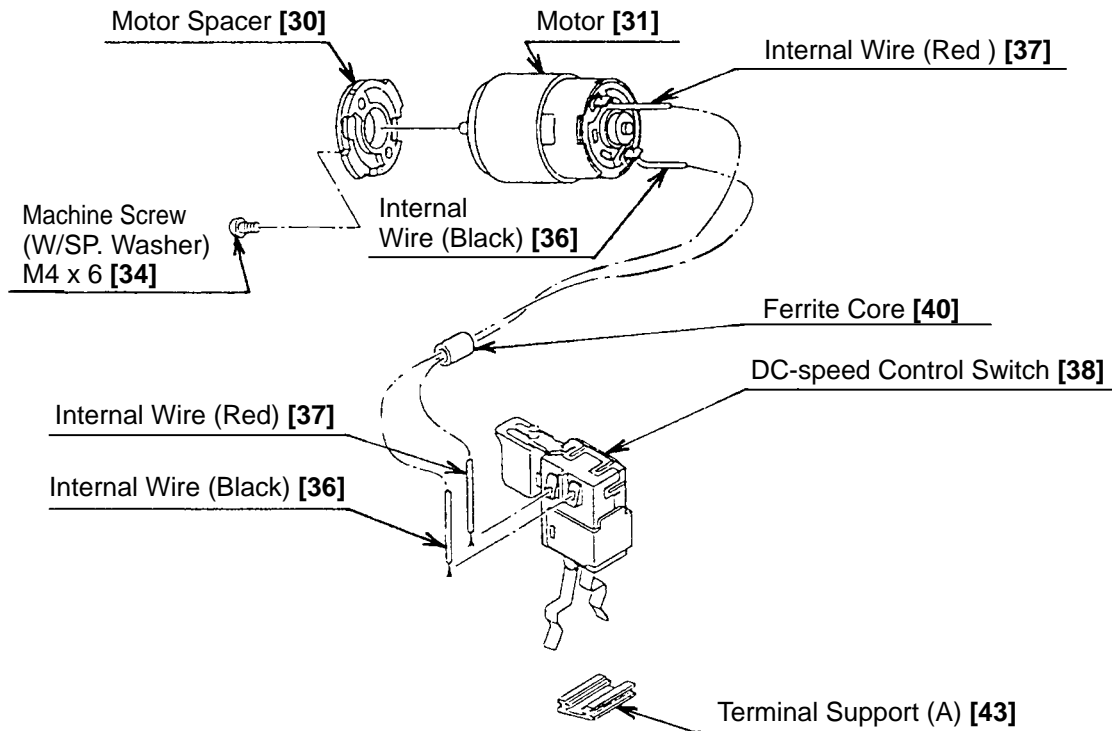

Fig. 7

(b) Pay attention to the polarity of the Motor [31] when soldering Internal Wires (Black) [36] and (Red) [37] to the Motor [31]. The red-marked side of the Motor [31] is positive. (See Fig. 8.)

(c) Apply grease (Hitachi Motor Grease No. 29, Code No. 930035 is recommended) to the pinion press-fitted on the Motor [31] shaft.

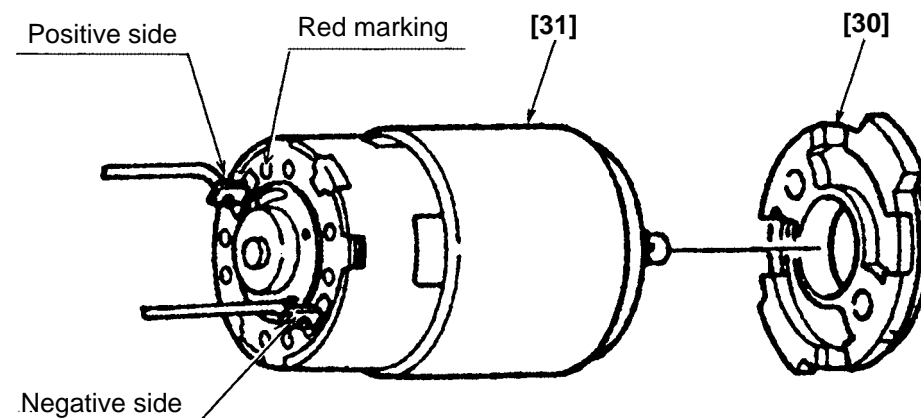

Fig. 8

(2) Reassembly of the clutch unit

Mount the Thrust Washer [11], Spring [10] and Nut [9] to the Front Case [12].

Screw the Nut [9] in the Front Case [12] about 1-3/8 turns (495°). Mount the Switch Plate [8] aligning with the projections of the Front Case [12] as shown in Fig. 5.

(3) Reassembly of the gear unit

(a) Apply grease (Hitachi Motor Grease No. 29, Code No. 930035) to the meshing parts of the gear.

(b) Install the parts series from the six Rollers [13] to Washer (B) [29] into the assembly reassembled in step (2). (See Fig. 9.)

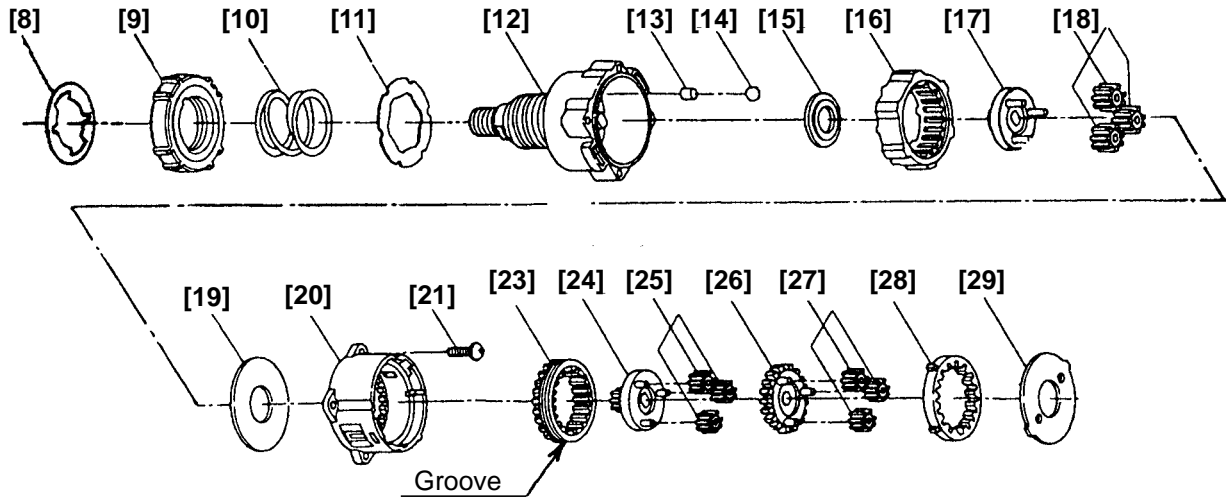

Fig. 9

(i) Note the direction of the groove when installing the Slide Ring Gear [23] so that the groove faces toward the Motor [31].

(ii) Install Washer (B) [29] in the Rear Case [20] with the projections of Washer (B) [29] engaged with the recesses in the Rear Case [20], and turn Washer (B) [29] clockwise until it can turn no further.

(See Fig. 10.)

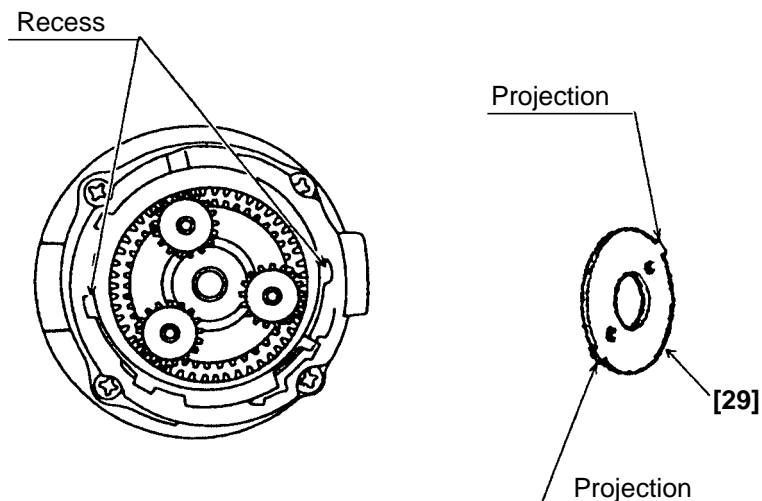

Fig. 10

- (c) Install the Click Spring [5] and the Cap [4] to the assembly reassembled in step (b). (See Fig. 11.)
- (i) Insert the ridge and the projections of the Click Spring [5] into the holes of the Cap [4].
- (ii) When the Nut [9] is screwed in the Front Case [12] about 1-3/8 turns (495°), the three projections of the Nut [9] and the marking of the Rear Case [20] are positioned as shown in Fig. 11. Set the narrow slit of switch flange as shown in Fig. 11. Mount the Cap [4] aligning the ridge of the Click Spring [5] with the three projections of the Nut [9].

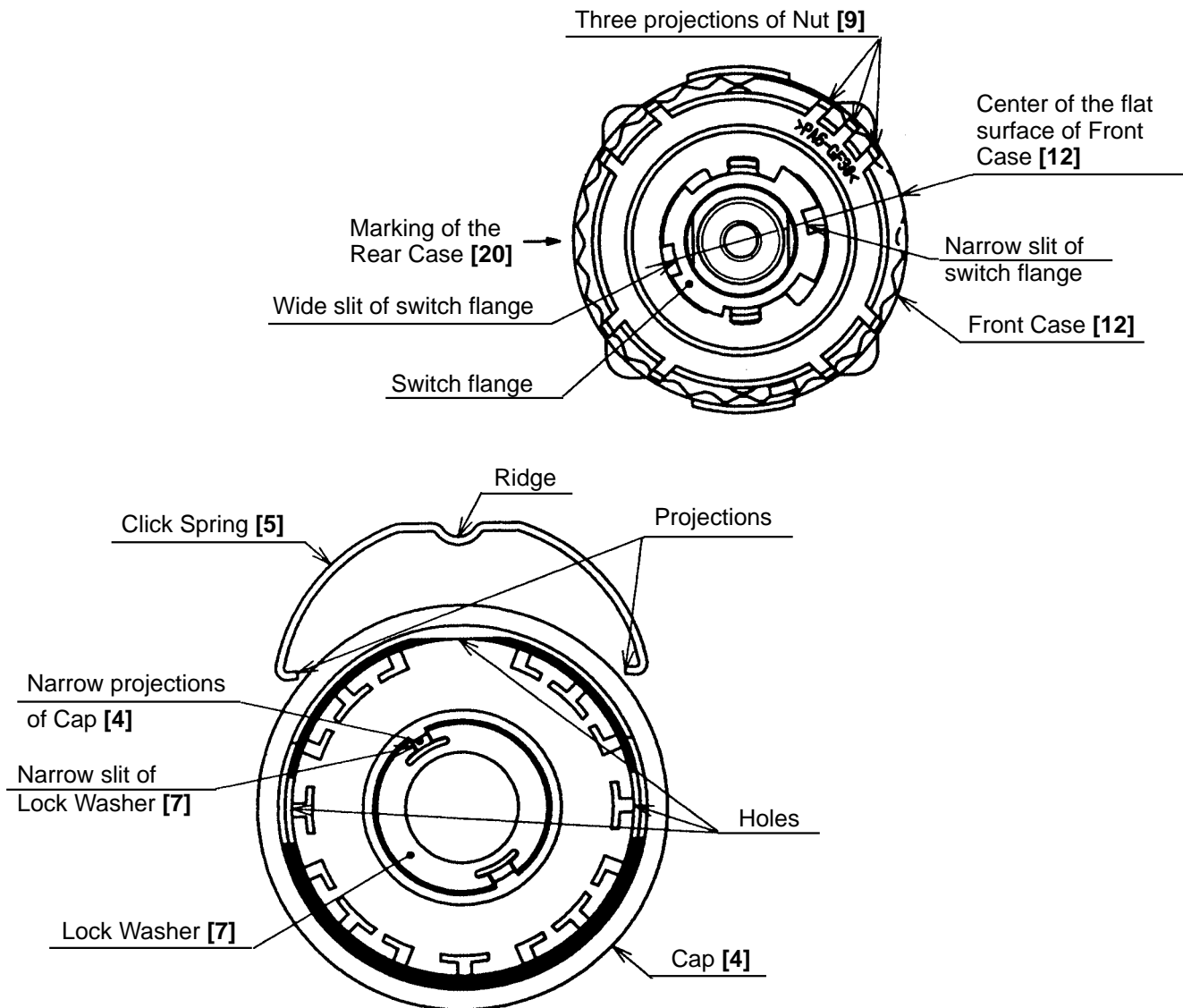

Fig. 11

(d) Install the Shift Arm [22] into the assembly reassembled in step (c).

With the ridge at the Shift Arm [22] facing the Motor [31] side, first install them on the unmarked side of the assembly reassembled in step (c). Then insert the projections on the Shift Arm [22] into the holes in the Rear Case [20] and make sure that the projections are fitted into the grooves in the Slide Ring Gear [23] mounted within the Rear Case [20]. (See Fig. 12.)

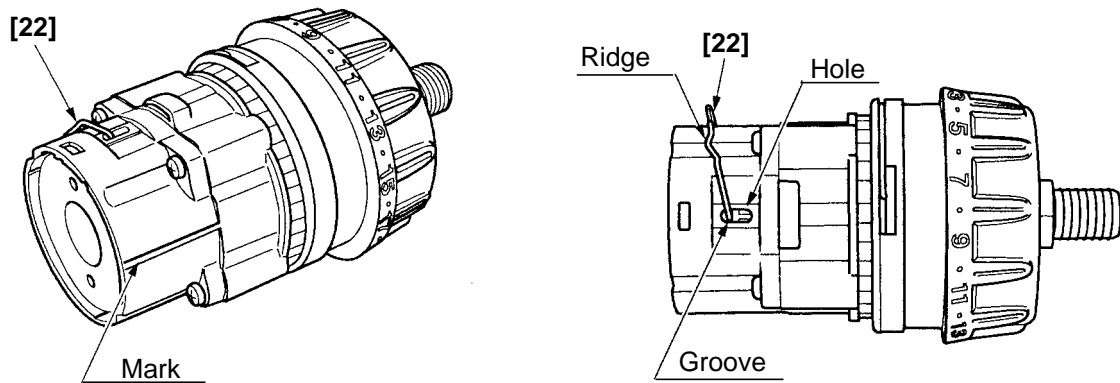

Fig. 12

(e) Install the Drill Chuck 13VLRN-N (W/O Chuck Wrench) [2].

Install the Drill Chuck 13VLRN-N (W/O Chuck Wrench) [2] using the Wrench 14 mm (special repair tool, Code No. 873929) and secure it with the Special Screw (Left Hand) M6 x 23 [1].

(f) Install the Shift Knob [41] into the assembly reassembled in step (e).

When installing the Shift Knob [41] into the Shift Arm [22], note that the "LOW" mark on the Shift Knob [41] faces the Motor [31] with the Shift Arm [22] engaged with the recess in the Shift Knob [41].

(g) Install the assembly reassembled in step (1) and the assembly reassembled in step (f) together. (See Fig. 13.)

Fit the projection on the Motor Spacer [30] into the recess in the Rear Case [20] while ensuring that the Shift Knob [41] is aligned with the positive side of the Motor [31] and turn the Motor Spacer [30] clockwise when viewed from the rear of the Motor [31] until it can turn no further. During installation, make sure that the pinion press-fitted onto the shaft of the Motor [31] and Planet Gear (A) Set (3 pcs.) [27] mesh properly.

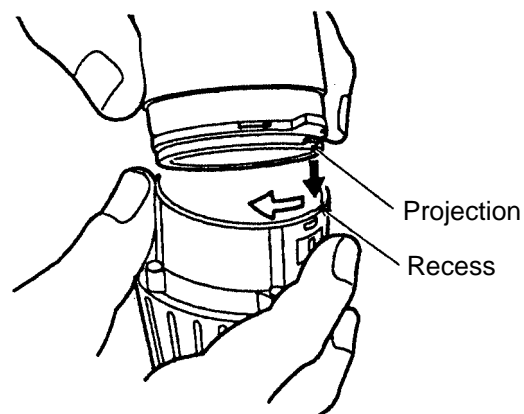

Fig. 13

(4) Installation of the assembly reassembled in step (3) into Housing (A). (B) Set [35]

(a) Install the Pushing Button [39] into Housing (B) [35]. (See Fig. 14.)

(b) Install the assembly reassembled in step (3) into Housing (A) [35]. Note that the projections on the Front Case [12] and the Motor Spacer [30] are engaged in the recesses in Housing (A) [35], and the projection on Housing (A) [35] is engaged in the groove of the Cap [4]. (See Fig. 15.)

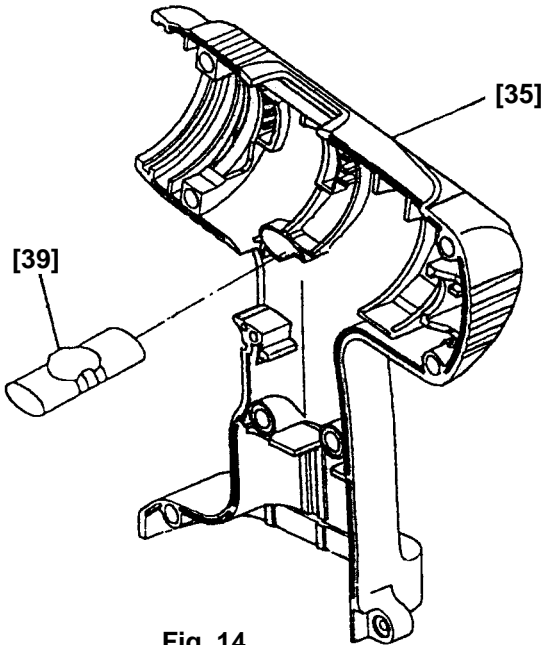

Fig. 14

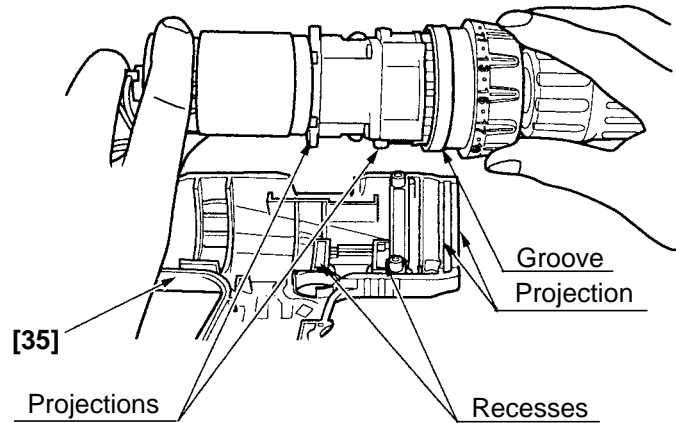



Fig. 15

(c) Set the assembly reassembled in step (b) to Housing (B) [35] and secure it with the eight Tapping Screws (W/Flange) D3 x 16 (Black) [32].

(d) Verify proper operation of the Cap [4].

When the assembly procedure up to step (c) is completed, ensure that the number "1" on the Cap [4] and the impact mark "  " are in alignment with the triangle mark on Housing (A). (B) Set [35]. If the Cap [4] turns loosely, correctly reinstall the Click Spring [5] as it is improperly installed. If the number "1" on the Cap [4] or the impact mark "  " cannot reach the triangle mark on Housing (A). (B) Set [35], correctly reinstall the Cap [4] referring to step (3) (c), as it is improperly installed.

(5) Other precautions in reassembly

(a) When the assembly procedure is completed, make sure that the turning direction of the Drill Chuck 13 VLRN (W/O Chuck Wrench) [2] corresponds to the position of the Pushing Button [39]. When the Pushing Button [39] is pressed from the (R)-marked side, the Drill Chuck 13VLRN (W/O Chuck Wrench) [2] should turn clockwise when viewed from the rear (opposite side of the Drill Chuck 13VLRN (W/O Chuck Wrench) [2]). Also make sure that the turning speed of the Drill Chuck 13VLRN (W/O Chuck Wrench) [2] switches between "HIGH" and "LOW" by switching over the Shift Knob [41]. Make sure that the run-out of the Drill Chuck 13VLRN (W/O Chuck Wrench) [2] holding a 12 mm dia. test bar is below 0.8 mm at a distance of 110 mm from the chuck end.

(b) The tightening torque of each screw is given below.

Special Screw (Left Hand) M6 x 23 [1]	: 2.9 – 3.9 N•m (30 – 40 kgf•cm, 26.1 – 34.8 in-lbs.)
Drill Chuck 13VLRN (W/O Chuck Wrench) [2]	: 12.7 – 16.7 N•m (130 – 170 kgf•cm, 113 – 148 in-lbs.)
Screw Set M3 x 12 (4 pcs.) [21]	: 0.6 – 1.0 N•m (6 – 10 kgf•cm, 5.2 – 8.7 in-lbs.)
Machine Screw (W/SP. Washer) M4 x 6 [34]	: 1.1 – 1.9 N•m (11 – 19 kgf•cm, 9.5 – 16.5 in-lbs.)
Tapping Screw (W/Flange) D3 x 16 (Black) [32]	: 1.1 – 1.9 N•m (11 – 19 kgf•cm, 9.5 – 16.5 in-lbs.)

10-2. Precautions in Disassembly and Reassembly of Battery Charger

Please refer to the Technical Data and Service Manual for precautions in disassembly and reassembly of the Battery Charger UC 24YFA.

11. STANDARD REPAIR TIME (UNIT) SCHEDULES

MODEL	Variable		10	20	30	40	50	60
	Fixed							
DV 18DV		Work Flow						
	General Assembly	Spring Drill Chuck Housing (A).(B) Set Motor Cap DC-speed Control Switch O-ring Nut Shift Arm (Gear Box Ass'y) Front Case Ring Gear Carrier First Ring Gear Planet Gear (A) Set Pinion (B) Planet Gear (B) Set Pinion (C) Slide Ring Gear Planet Gear (C) Set Rear Case						

ELECTRIC TOOL PARTS LIST



■ CORDLESS IMPACT DRILL

2001・5・10

Model DV 18DV

(E1)

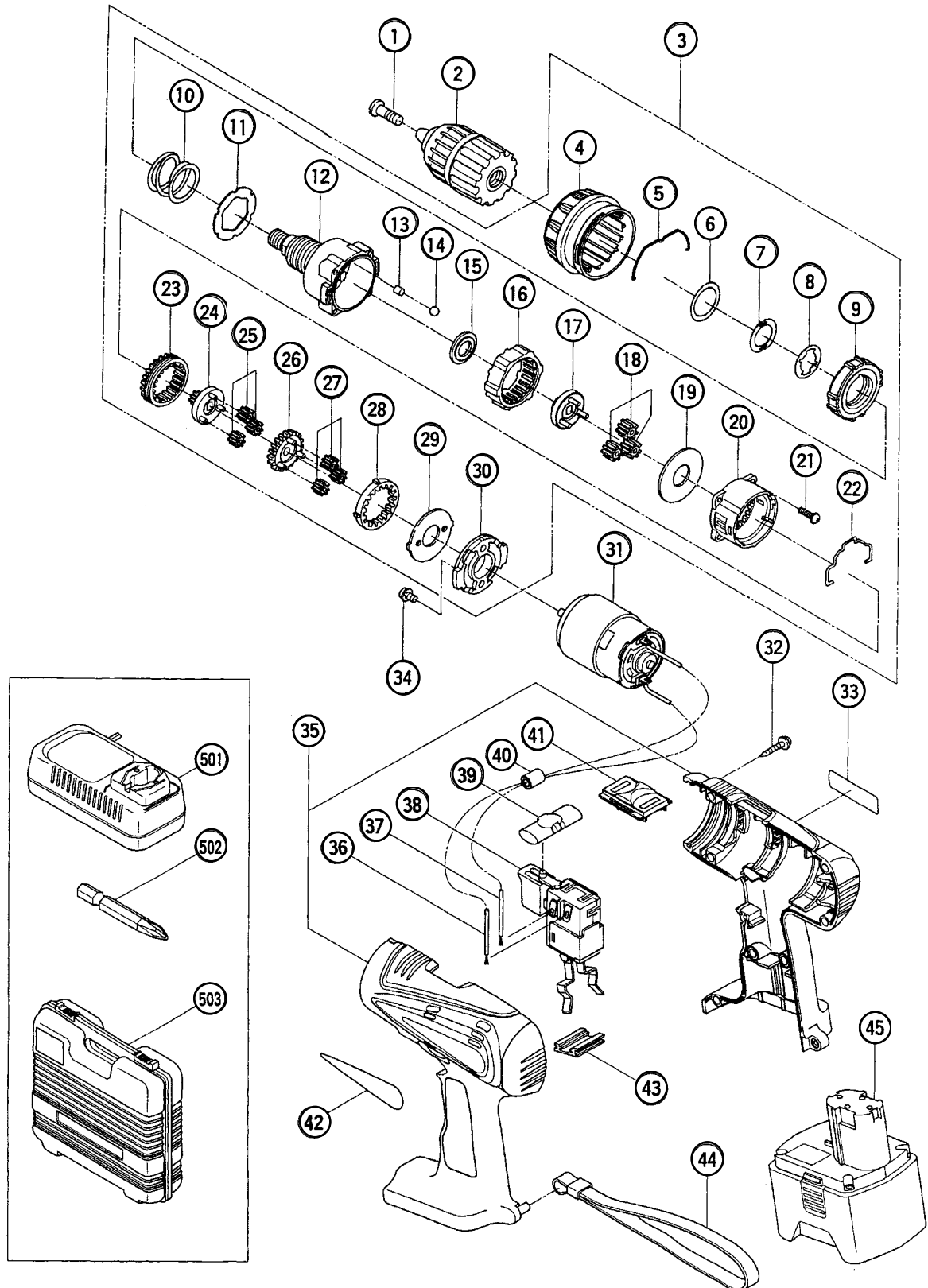

PARTS

DV 18DV

ITEM NO.	CODE NO.	DESCRIPTION	NO. USED	REMARKS		
1	311-959	SPECIAL SCREW (LEFT HAND) M6X23	1			
2	319-766	DRILL CHUCK 13VLR-F-N (W/O CHUCK WRENCH)	1			
3	320-093	GEAR BOX ASS'Y	1	INCLUD.4-30		
4	319-963	CAP	1			
5	319-754	CLICK SPRING	1			
6	320-088	O-RING	1			
7	320-089	LOCK WASHER	1			
8	320-090	SWITCH PLATE	1			
9	319-743	NUT	1			
10	319-742	SPRING	1			
11	319-741	THRUST WASHER	1			
12	320-092	FRONT CASE	1			
13	319-744	ROLLER	6			
14	306-936	STEEL BALL D5	6			
15	319-746	SPACER WASHER	1			
16	319-745	RING GEAR	1			
17	319-747	CARRIER	1			
18	319-769	PLANET GEAR (C) SET (3 PCS.)	3			
19	312-704	WASHER (A)	1			
20	319-748	REAR CASE	1			
21	320-087	SCREW SET M3X12 (4 PCS.)	4			
22	319-753	SHIFT ARM	1			
23	319-750	SLIDE RING GEAR	1			
24	319-749	PINION (C)	1			
25	319-768	PLANET GEAR (B) SET (3 PCS.)	3			
26	319-751	PINION (B)	1			
27	319-767	PLANET GEAR (A) SET (3 PCS.)	3			
28	319-752	FIRST RING GEAR	1			
29	312-716	WASHER (B)	1			
30	316-955	MOTOR SPACER	1			
31	319-756	MOTOR	1			
32	313-687	TAPPING SCREW (W/FLANGE) D3X16 (BLACK)	8			
33		MANE PLATE	1			
34	317-333	MACHINE SCREW (W/SP. WASHER) M4X6	2			
35	319-761	HOUSING (A).(B) SET	1			
*	36	319-759	INTERNAL WIRE (BLACK) 100L	1		
*	36	320-159	INTERNAL WIRE (BLACK) 160L	1	FOR GBR,FRG,NOR,SWE,DEN	
	37	319-758	INTERNAL WIRE (RED) 130L	1		
	38	320-091	DC-SPEED CONTROL SWITCH	1		
	39	319-760	PUSHING BUTTON	1		
*	40	318-247	FERRITE CORE	1	FOR GBR,FRG,NOR,SWE,DEN	
	41	318-234	SHIFT KNOB	1		
	42		HITACHI LABEL	1		
	43	315-141	TERMINAL SUPPORT (A)	1		
	44	306-952	STRAP (BLACK)	1		
*	45	319-762	BATTERY EB 1820 (W/ENGLISH N.P)	2		
*	45	319-763	BATTERY EB 1820 (W/ENGLISH N.P)	2	FOR USA,CAN	
*	45	319-764	BATTERY EB 1820 (W/ENGLISH N.P)	2	FOR GBR,FRG	
*	45	319-765	BATTERY EB 1830H (W/ENGLISH N.P)	2		

* ALTERNATIVE PARTS

5 - 01

